



# PRO-WEI100

## WEIGHING CONTROLLER MANUAL



### PRO-WEI100

PRO series weighing controller

- I	Indicator only
- R4	4 x relay outputs
A	1 x analog output
S	1 x serial port
- HV	85-265V AC / 95-370V DC power
- LV	15-48V AC / 10-72V DC power

# 1 INTRODUCTION

This intelligent weighing controller interfaces smoothly with a wide range of PLC and monitoring systems. It is designed to relieve the PLC of processing overhead, reduce costs and extend the capability of the total system. The controller is straightforward to use, and has a built-in alphanumeric LED display and five front-panel buttons. Designed specifically for use in weighing applications, it comes pre-calibrated to suit either a 4-wire or a 6-wire strain gauge input. Setup is simple, with on-screen, step-by-step instructions.

This sophisticated instrument features output and input isolation, eliminating the need for any special consideration when interfacing to analogue/serial inputs, or PC's/PLC's/HMI's. It can be customised to include a serial port and an analogue output. Up to four relay outputs can also be added.

<b>1 - Introduction</b> .....	2
<b>2 - General Information</b> .....	3
<b>3 - Casing &amp; Display</b> .....	4
<b>4 - Wiring</b> .....	7
<b>5 - Setup &amp; Calibration</b> .....	10
<b>6 - Setpoint Setup</b> .....	20
<b>7 - Factory Analogue Output Cal</b> .....	23
<b>8 - Setpoint Easy Access</b> .....	24
<b>9 - Reset PIN Numbers</b> .....	25

## APPENDICES

<b>A - Tare &amp; Batch Features</b> .....	26
<b>B - Input Functions</b> .....	28
<b>C - Zero Maintenance</b> .....	29
<b>D - Serial Modes</b> .....	30

## 2

## GENERAL INFORMATION

<b>Input</b>	4/6-wire strain gauge, 1-5mV/V
<b>Power supply</b>	HV (85-265V AC/95-370V DC) <b>or</b> LV (15-48V AC/10-72V DC)
<b>Power (max)</b>	5W, fully optioned, 8 loadcells
<b>Easy setup</b>	Intuitive text prompts for easy setup.
<b>Calibration</b>	Pre-calibrated for 0-10,000 counts (2mV/V sensor gain at full scale). Can be recalibrated using the auto (apply mass) or mV/V method. Adjustable zero offset.
<b>Security</b>	Calibration and setpoint functions have independent security code access. Setpoint functions are independently configurable, and accessible through the <b>F2</b> key.
<b>Excitation</b>	5V DC excitation supplied (powers up to 8 x 350Ω loadcells).
<b>Sampling rate</b>	Up to 50Hz
<b>Resolution</b>	18-bit
<b>Accuracy</b>	0.005% of reading
<b>Temp. drift</b>	Typically 3ppm/°C

## OPTIONAL OUTPUTS

<b>Analogue output</b>	Isolated 16-bit 4-20mA/0-10V output (fully scaleable). 7 updates/sec. Window programmable over any range within the full-scale range of the controller
<b>Serial port</b>	Isolated RS232 or RS485 <i>Modes:</i> ASCII, Modbus RTU slave, Ranger A output (5 updates/sec). <i>Data rates:</i> 300-38400. <i>Parity:</i> Odd, even or none.
<b>Relay outputs</b>	4 x 5A Form A relays

**3 CASING & DISPLAY****3.1 Case dimensions**

**Dimensions** 48 x 96 x 119.5mm (H x W x D)

**Panel cutout** 45.5 x 92.5mm (H x W)

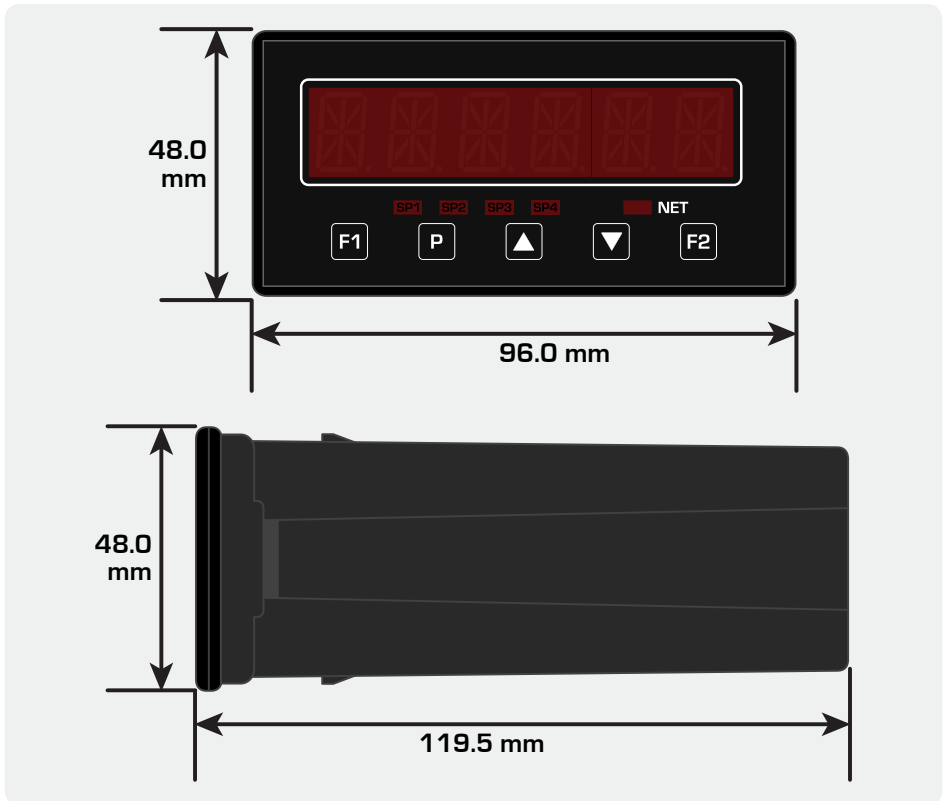

## 3.2 Front panel

The front panel has a 6-digit, 14-segment alphanumeric LED display and five front-panel buttons. It also includes four setpoint LED's and one NET annunciator.

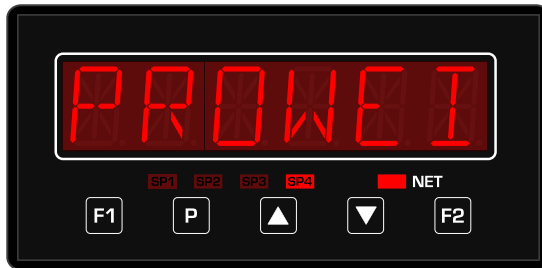

**SPX** The setpoint LED's are used to indicate active setpoints.

**NET** The net LED is indicates when the net value is being displayed, and is used for the **FLASH GROSS** function, which toggles between net and gross values. (See 5.2L)

**F1** This button is used to access the **Input Setup & Calibration** menu. See section 5.

**P** This button is typically used to save your settings and advance to the next step in the setup process. The function of a single keypress of this button from the operational display can be user programmed - see 5.2H.

**▲** This button is typically used to scroll through options or increase values in the setup menu. Pressing this button from the main display will allow you to view/reset the peak value and view the mV value of the input (see 3.3).

**▼** This button is typically used to scroll through options or decrease values in the setup menu. Pressing this button from the main display will allow you to view/reset the valley value (see 3.3).

**F2** This button is used to access the **Setpoint Setup** menu (see section 6) and the **Setpoint Easy Access** menu (see section 8).

### 3.3 Display shortcuts (view mode)

Press **P** at any time to return to the main display.

- ▲ Used to view/reset the **PEAK** value and to view the input value in mV.
  - Press the ▲ button once from the main display. **PEAK** appears and toggles with the maximum measured weight value since the instrument was turned on (or reset). To reset **PEAK**, press both the ▲ and ▼ buttons together now.
  - Press the ▲ button again. **MV** appears and toggles with the current value of the input signal in mV.
  
- ▼ Used to view/reset the **VALLEY** value.
  - Press the ▼ button once from the main display. **VALLEY** appears and toggles with the minimum measured weight value since the instrument was turned on (or reset). To reset **VALLEY**, press both the ▲ and ▼ buttons together now.

### 3.4 Display brightness

- A Press the **P** and ▲ buttons together from the operational display. **BRI** appears on the display and toggles with the current brightness setting.
  
- B Use the ▲ and ▼ buttons to adjust the brightness of the LED backlight as required, and then press **P**. The display returns to normal operating mode.

## 4 WIRING

### 4.1 Pinouts

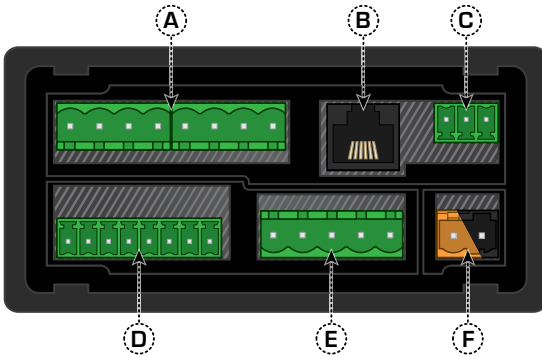

- (A)** 4 x relays (see 4.5)

---

- (B)** Serial port (see 4.6)

---

- (C)** Analogue output (see 4.4)

---

- (D)** Loadcell input (see 4.3)

---

- (E)** Function pins (see 4.7)

---

- (F)** Power supply (see 4.2)

### 4.2 Power supply

(see 4.1F)

**Before you begin**, determine whether your controller is configured for low or high voltage power supply. Check the label on the unit against the colour of the connector: **Orange** = high voltage (85-265V AC, 95-370V DC), **Black** = low voltage (15-48V AC, 10-72V DC).

**REMEMBER TO SWITCH YOUR POWER SUPPLY OFF BEFORE YOU BEGIN WIRING**

**NEVER CONNECT YOUR LOW VOLTAGE CONTROLLER TO MAINS POWER.**

**High voltage (HV)**

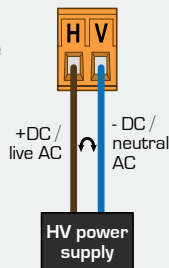

**Low voltage (LV)**

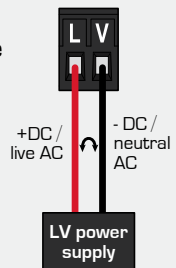

### 4.3 Loadcell input module (see 4.1D)

Wire your loadcell input module as shown in the diagram.

This input module is pre-calibrated for 0-10,000 counts full scale with a 2.000mV/V load cell sensor.

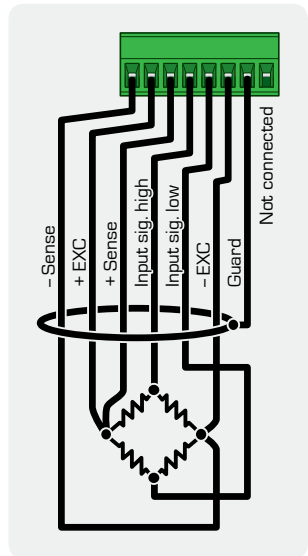

### 4.4 Analogue output (if fitted) (see 4.1C)

If your controller has analogue output fitted, wire it as shown. If you do not have analogue output fitted then skip this step.



### 4.5 Relays (if fitted) (see 4.1A)

If your controller has relays fitted, wire them as shown. Relays can be programmed to operate within the total span range of the controller.

If you do not have relays fitted then skip this step.

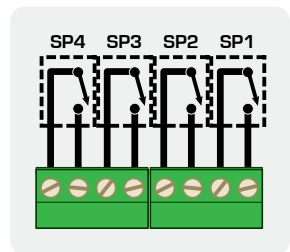

## 4.6 Serial port (if fitted) (see 4.1B)

If your controller has a serial port fitted, wire it as per the appropriate diagram.

If you do not have a serial port fitted then skip this step.

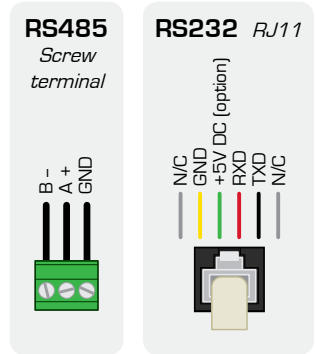

## 4.7 Function pins (if required) (see 4.1E)

Connect switches as required between the function pins.

Pin functions are user configurable, and can be set up in 5.2HK.

See Appendix B for a list of input functions.

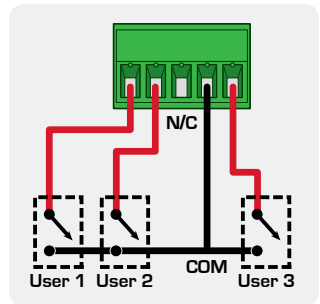

## 4.8 Power up

Once you have completed the wiring process it is safe to switch on your power supply. Ensure that your display is functioning before you proceed.

## 5 SETUP & CALIBRATION

### 5.1 Enter calibration PIN



**YOU WILL HAVE THE OPPORTUNITY TO CHANGE YOUR PIN NUMBER AT THE END OF THIS SECTION (5.8). IF YOU HAVE FORGOTTEN YOUR PIN NUMBER, SEE SECTION 9.**

- A Enter the calibration mode by pressing **F1**.  
 \_\_\_ **ENTER CAL PIN** scrolls across the display and toggles with **0**. Use the **▲** and **▼** buttons to enter your security code (factory default 1). Then press **P**. If the correct PIN is entered then the setup is started at 5.2.  
 If an incorrect PIN number is entered, \_\_\_ **ACCESS DENIED** scrolls across the display and it returns to the normal operating mode.

### 5.2 Input setup

- A \_\_\_ **INPUT SETUP** scrolls across the display and toggles with **SKIP**. Press **P** to skip to 5.3, or the **▲** button and then **P** to **ENTER** input setup.
- B \_\_\_ **SAMPLING RATE** scrolls across the display and toggles with the selection. Use the **▲** and **▼** buttons to select: **1HZ**, **10HZ** (default) or **50HZ**. Press **P**.
- C \_\_\_ **DECIMAL POINT POSITION** scrolls across the display and toggles with the current selection. Using the **▲** and **▼** buttons, select: **NO DP**, **0.0**, **0.00**, **0.000** or **0.0000**. Then press **P**.
- D \_\_\_ **ROUNDING** scrolls across the display and toggles with the current display rounding. Use the **▲** and **▼** buttons to select: **NONE**, **2**, **5** or **10**. Press **P**.



*Rounding is quoted in display counts and is not influenced by decimal point position. (Eg. If your input signal is 5.3, the display will show: 5.3 at **NONE**, 5.4 at **2**, 5.5 at **5**, or 5.0 at **10**).*

- E** **\_\_\_ MODE** scrolls across the display and toggles with the current weighing mode. Use the  and  buttons to select **NORMAL** (default) or **BATCH**, and press .





*In **NORMAL** (default) mode the controller displays the gross or net weight on the display, and does not perform any batch calculations. In **BATCH** mode the controller displays batch or gross weight, and SP 1 and SP 2 function as dedicated batch control setpoints. Refer to Appendix A.2 for additional information.*



- F**  **If you selected NORMAL in 5.2E:**



Skip step 5.2G and continue to 5.2H now.



- G** **\_\_\_ BATCHING DIRECTION** scrolls across the display and toggles with current selection. Use the  and  buttons to select either: **NEG** (negative, for emptying operations) or **POS** (positive, for filling operations). Then press .



*Refer to Appendix A.2 for additional information.*

- H** **\_\_\_ PROG BUTTON** scrolls across the display and toggles with the current selection. Use the  and  buttons to select a function<sup>1</sup> to be performed when the  button is pressed from the operational display: **HOLD**, **TARE/BATCH**<sup>2</sup>, **ZERO**, **PEAK**, **PK RST** or **PRINT**. Then press .

- I** **\_\_\_ USER INPUT1** scrolls across the display and toggles with the current selection. Use the  and  buttons to select a function<sup>1</sup> to be performed when the User 1 input pin<sup>3</sup> at the rear of the meter is activated: **LOCK**, **TARE/BATCH**<sup>2</sup>, **ZERO**, **PEAK**, **PK RST** or **PRINT**. Then press .

- J** **\_\_\_ USER INPUT2** scrolls across the display and toggles with the current selection. Use the  and  buttons to select a function<sup>1</sup> to be performed when the User 2 input pin<sup>3</sup> at the rear of the meter is activated: **HOLD**, **TARE/BATCH**<sup>2</sup>, **ZERO**, **PEAK**, **PK RST** or **PRINT**. Then press .

**K** \_ \_ \_ **USER INPUT3** scrolls across the display and toggles with the current selection. Use the  and  buttons to select a function<sup>1</sup> to be performed when the User 3 input pin<sup>3</sup> at the rear of the meter is activated: **TARE/BATCH**<sup>2</sup>, **ZERO**, **PEAK**, **PK RST** or **PRINT**. Then press .

**L** \_ \_ \_ **FLASH GROSS** scrolls across the display and toggles with the currently selected setting. Using the  and  buttons, select **NO** or **YES**. Press .

*This will cause the display to toggle between the Net/Gross values for 3 seconds each. Toggling will only occur if the controller has been tared and the Net/Gross values are different. The NET LED indicates which value is being displayed (On: Net, Off: Gross). This option will be disabled if a batch is currently in progress.*

- 1 For more information on available functions, see Appendix B.
- 2 **TARE/BATCH** options are subject to the weighing mode selected in 5.2E above. (**NORMAL** mode = **TARE** option, **BATCH** mode = **BATCH** option.) See Appendix A.
- 3 See 4.7 to wire rear input pins.





## 5.3

### Calibration

**WHEN CALIBRATION IS COMPLETE, YOU WILL BE AUTOMATICALLY DIRECTED BACK TO THE OPERATIONAL DISPLAY. TO ENTER STEP 5.4, YOU MUST SELECT SKIP AT 5.3A.**

**STOP!**

DO YOU NEED TO CALIBRATE? THIS UNIT HAS BEEN PRECALIBRATED FOR 0-10,000 COUNTS (2mV/V SENSOR GAIN AT FULL SCALE).

**A** \_ \_ \_ **CALIBRATION TECHNIQUE** scrolls across the display and toggles with **SKIP**. Press  to skip to 5.4, or use the  and  buttons to select: **AUTO**, **MV/V**, **ZERO** or **E\_CAL**. Then press .

***AUTO** calibration uses zero and span values to calculate the scale and offset. This is the most accurate calibration method, but requires known low and high input signals, usually supplied by test weights. Zero and span calibration procedures are performed separately. **MV/V** uses values from the load cell manufacturer's test certificate. **ZERO** allows manual adjustment of the calibrated zero offset. **E\_CAL** allows the user to view and edit the electronic calibration values (zero offset and scale factor). These two values are updated when any calibration is performed. Noting these values and entering them into another instrument will copy the calibration. You may also 'trim' these values to alter the current calibration.*

**B** The step that you proceed to now will depend on your selection in 5.3A.

**AUTO:** Complete steps 5.3C-I



**ZERO:** Complete steps 5.3N-O

**MV/V:** Complete steps 5.3J-M

**E\_CAL:** Complete steps 5.3P-R



Please note that following calibration you will be automatically directed back to the operational display. To enter step 5.4, you must select **SKIP** at 5.3.



▶▶ AUTO CALIBRATION METHOD ▶▶

**C** \_\_\_ **CALIBRATE ZERO** scrolls across the display and toggles with the current selection. Use the  and  buttons to select **NO** or **YES**, and then press .

**D**  **If you selected NO in 5.3C:**



Skip step 5.3E and continue to 5.3F now.

**E** \_\_\_ **REMOVE WEIGHT - PRESS P TO ACCEPT** scrolls across the display and toggles with the current no-load value. Remove the weight. Use the  and  buttons to adjust the no-load value if required. Then press .

**F** \_\_\_ **CALIBRATE SPAN** scrolls across the display and toggles with the current selection. Use the  and  buttons to select **NO** or **YES**, and then press .









**G**  **If you selected NO in 5.3F:**

Skip step 5.3H and continue to 5.3I now.



**H** \_\_\_ **ADD CAL WEIGHT - ENTER DESIRED SPAN - PRESS P TO ACCEPT** scrolls across the display and toggles with the current span value. Apply a calibration weight to the weigh platform. Then use the  and  buttons to adjust the value, and press  to accept.

- I If **AUTO** calibration was successful, you will be directed out of the calibration menu to the operational display without viewing any further scrolling messages. If calibration fails, **\_\_\_ CALIBRATION FAILED** will scroll across the display twice and you will be directed out of the calibration menu to the operational display. Check your signal and connections, and then repeat the calibration procedure.







▶▶ **MV/V METHOD** ▶▶

- J **\_\_\_ ENTER TOTAL FULL SCALE WEIGHT OF LOAD CELLS IN COUNTS** scrolls across the display and toggles with the current selection. Using the  and  buttons, enter the total full scale weight of the connected load cell(s) in counts - refer to the load cell manufacturer's test certificate. Then press .
- K **\_\_\_ ENTER MV/V FROM LOAD CELL** scrolls across the display and toggles with the current selection. Using the  and  buttons, enter the mV/V (or average mV/V) of the connected load cell(s). Press .
- L **\_\_\_ SET ZERO NOW ?** scrolls across the display and toggles with the current selection. Use the  and  buttons to select **NO** or **YES**, and then press .
- Selecting **YES** sets your zero position when the load cells are powered up and in position.*
- M **MV/V** calibration is now complete. You will be directed to the operational display.

▶▶ **ZERO (OFFSET) CALIBRATION** ▶▶







- N **\_\_\_ ADJUST OFFSET** scrolls across the display and toggles with the currently selected zero value. Place a known weight on the weigh platform if required, and then use the  and  buttons to enter the desired value. Press  to accept.
- The offset will be automatically calculated to match the desired weight, and the scale factor will not be altered. Normally the weight would be removed and the desired value would be zero.*
- O **ZERO** calibration is now complete. You will be directed to the operational display.

▶▶ E-CAL METHOD ▶▶

- P** \_\_\_ **E\_CAL ZERO OFFSET** scrolls across and toggles with the current selection. Use the  and  buttons to adjust the zero offset value, and then press .
- After a calibration has been performed, the **E\_CAL ZERO OFFSET** value shows the resulting zero offset.*
- Q** \_\_\_ **E\_CAL SCALE FACTOR** scrolls across and toggles with the current selection. Use the  and  buttons to adjust the scale factor value, and then press .
- After a calibration has been performed, the **E\_CAL SCALE FACTOR** value shows the resulting scale factor.*
- R** **E\_CAL** calibration is now complete. You will be directed out of the calibration menu to the operational display.

## 5.4 Zero maintenance

▶▶ 5.4 Quick Access from main display ▶▶ Press . Use  &  to enter PIN. Press  3 times.

- A** \_\_\_ **ZERO MAINTENANCE** scrolls across the display and toggles with **SKIP**. Press  to skip to 5.5, or the  button and then  to **ENTER** zero maintenance.
- B** \_\_\_ **AUTO ZERO** scrolls across the display and toggles with the current auto zero selection. Use the  and  buttons to select **OFF** or **ON**, and press .
- If **AUTO ZERO** mode is **ON**, the controller's offset will be automatically adjusted so that the instrument reads zero when it senses that the scale is not loaded. [See Appendix C.]*

- C**  **If you selected OFF in 5.4B:**

Skip steps 5.4D-E and continue to 5.4F now.

- D** \_\_\_ **CAPTURE BAND** scrolls across the display and toggles with the selected capture band. Adjust this value using the  $\blacktriangle$  and  $\blacktriangledown$  buttons, and then press  $\text{P}$ .
- E** \_\_\_ **MOTION BAND** scrolls across the display and toggles with the selected motion band. Adjust this value using the  $\blacktriangle$  and  $\blacktriangledown$  buttons, and then press  $\text{P}$ .
- F** \_\_\_ **ZERO BAND** scrolls across the display and toggles with the selected zero band. Adjust this value using the  $\blacktriangle$  and  $\blacktriangledown$  buttons, and then press  $\text{P}$ .

## 5.5 Averaging

- A** \_\_\_ **AVERAGING PARAMETERS** scrolls across the display and toggles with **SKIP**. Press  $\text{P}$  to skip to 5.6, or the  $\blacktriangle$  button and then  $\text{P}$  to **ENTER**.

**AVERAGING** - Your controller has input signal averaging, optimising stable measurement.

If the change in input exceeds the averaging window value it will not average, ensuring fast response when there are large differences between readings. (E.g. When a product is being dropped into a bag).

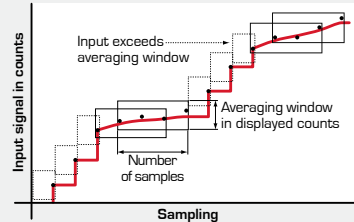

- B** \_\_\_ **AVE SAMPLES** scrolls across the display and toggles with the currently selected averaging. Using the  $\blacktriangle$  and  $\blacktriangledown$  buttons, alter the number of input samples that the controller will average, and then press  $\text{P}$ .

*Increasing the number of samples will stabilise measurement, but it will also slow down response rates. Typical value is 4.*

- C** **\_\_\_ AVE WINDOW** scrolls across the display and toggles with the currently selected averaging window value. Using the **▲** and **▼** buttons, alter the signal averaging window. Then press **P**.

*If your input signal contains large noise spikes, then you can increase the size the of averaging window to ensure that these pulses are still averaged. However, increasing the averaging window too far will reduce the ability of the controller to respond quickly to real changes in input signal. A setting of 0 averages all reading. A typical value is 10% of your system capacity.*

## 5.6 Analogue output setup

**PLEASE SKIP SECTION 5.6 IF YOU DO NOT HAVE ANALOGUE OUTPUT INSTALLED.**

- A** **\_\_\_ ANALOG OUTPUT SETUP** scrolls across display and toggles with **SKIP**. Press **P** to skip to 5.7, or the **▲** button and then **P** to **ENTER** analogue output setup.

- B** **\_\_\_ DATA SOURCE FOR ANALOG O/P** scrolls across the display and toggles with the currently selected data source. Using the **▲** and **▼** buttons, select: **NET/BATCH** or **LIVE**, and then press **P**.

*NET/BATCH option is subject to the weighing mode selected in 5.2E. (NORMAL mode = NET option, BATCH mode = BATCH option.)*

- C** **\_\_\_ LOW SCALE VALUE FOR ANALOG O/P** scrolls across the display and toggles with the currently selected low scale value. Use the **▲** and **▼** buttons to set the low scale value. Then press **P**.

- D** **\_\_\_ HIGH SCALE VALUE FOR ANALOG O/P** scrolls across the display and toggles with the currently selected high scale value. Use the **▲** and **▼** buttons to set the high scale value. Then press **P**.

## 5.7 Serial setup

PLEASE SKIP SECTION 5.7 IF YOU DO NOT HAVE A SERIAL PORT INSTALLED. CONFIGURING THE SERIAL PORT WILL ALLOW YOU TO CONNECT YOUR CONTROLLER TO A PC OR ANOTHER DEVICE. FOR MORE INFORMATION ON SERIAL MODES, REGISTERS AND FORMATTING, SEE APPENDIX D.

**A** \_ \_ \_ **SERIAL SETUP** scrolls across the display and toggles with **SKIP**. Press **P** to skip to 5.8, or the **▲** button and then **P** to **ENTER** serial port setup.

**B** \_ \_ \_ **SERIAL MODE** scrolls across the display and toggles with the currently selected serial mode. Using the **▲** and **▼** buttons, select either: **ASCII** (custom), **MODBUS** (RTU) or **RNGR A** (Ranger A). Then press **P**.

*For more information on serial modes, registers and formatting, please see Appendix D.*

**C** \_ \_ \_ **SERIAL DATA SOURCE** scrolls across the display and toggles with the currently selected data source. Using the **▲** and **▼** buttons, select: **NET/BATCH** or **LIVE**, and then press **P**.









*NET/BATCH option is subject to the weighing mode selected in 5.2E. (NORMAL mode = NET option, BATCH mode = BATCH option.)*

**D**  **If you selected ASCII or MODBUS in 5.7B:**

Skip step 5.7E and continue to 5.7F now.

**E** \_ \_ \_ **RANGER OUTPUT MODE** scrolls across the display and toggles with the current selection. Use the **▲** and **▼** buttons to select either **CONT** (continuous) or **PULSED**. Then press **P**.







*In CONT (continuous) mode, the controller outputs a continuous stream of data. In PULSED mode, the controller outputs a single string when the print function is triggered from a user input button or pin (see 5.2HK and Appendix B).*

- F** \_\_\_ **BAUD RATE** scrolls across the display and toggles with the current selection. Using the  and  buttons, select either: **300, 600, 1200, 2400, 4800, 9600, 19200** or **38400**. Then press .
- G** \_\_\_ **PARITY** scrolls across the display and toggles with the currently selected parity. Using the  and  buttons, select: **NONE, ODD** or **EVEN**. Press .
- H** \_\_\_ **SERIAL ADDRESS** scrolls across the display and toggles with the currently selected serial address. Use the  and  buttons to alter the serial address. Then press .

*The serial address parameter is used to identify a particular device when it is used with other devices in a system. [It applies particularly to Modbus mode when used on an option 4 (RS485) serial network.] The serial address of the controller must be set to match the serial address defined in the master device.*

*For more information on serial modes, registers and formatting, please see Appendix D.*

## 5.8 Edit calibration PIN

- A** \_\_\_ **EDIT CAL PIN** scrolls across the display and toggles with **SKIP**. Press  to skip and return to the operational display, or the  button and then  to **ENTER** and change your PIN number.
- B** \_\_\_ **ENTER NEW CAL PIN** scrolls across the display and toggles with the current PIN (default 1). Using the  and  buttons, enter your new calibration PIN number. Then press  to exit and return to the operational display.

## 6 SETPOINT SETUP

### 6.1 Enter setpoint PIN

**YOU WILL HAVE THE OPPORTUNITY TO CHANGE YOUR PIN NUMBER AT THE END OF THIS SECTION (6.3). IF YOU HAVE FORGOTTEN YOUR PIN NUMBER, SEE SECTION 9.**



- A Enter the setpoint setup mode by pressing the **F2** button for 3 seconds. **\_\_ \_ ENTER SP PIN** scrolls across the display and toggles with **0**. Use the **▲** and **▼** buttons to enter your security code (factory default 1). Then press **P**. If the correct PIN is entered then the setup is started at 6.2. If an incorrect PIN number is entered, **\_\_ \_ ACCESS DENIED** scrolls across the display and it returns to the normal operating mode.

### 6.2 Edit setpoints

- A **\_\_ \_ EDIT SETPOINT** scrolls across the display and toggles with **SKIP**. Press **P** to skip to 6.3, or use the **▲** and **▼** buttons to select a setpoint to edit: **SP 1**, **SP 2**, **SP 3** or **SP 4**. Then press **P**.
- B **\_\_ \_ SP VALUE** scrolls across the display and toggles with the display value at which the setpoint will activate. Adjust using the **▲** and **▼** buttons, and then press **P**.

- C **!** **If you selected SP 1 in 6.2A:**



Skip step 6.2D and continue to 6.2E now.

- D** \_\_\_ **TRAIL SP1** scrolls across the display and toggles with the current selection. Use the  and  buttons to select **OFF** or **ON**, and then press .



*If you choose **ON**, the selected setpoint will be automatically adjusted whenever SP 1 is changed, so that the 2 setpoints always trail each other by the same amount. Note: Set negative polarity if the setpoint operates before SP 1.*

- E**  **If you selected BATCH in 5.2E AND SP 1 or SP 2 in 6.2A:**



**SP 1** and **SP 2** are reserved for batch functions when your controller is in **batching mode**. Skip steps 6.2F-J and continue to 6.2K now.

- F** \_\_\_ **SP SOURCE** scrolls across the display and toggles with the current setpoint source. Use the  and  buttons to select **NET/BATCH** or **LIVE**. Then press .

*NET/BATCH option is subject to the weighing mode selected in 5.2E. (NORMAL mode = NET option, BATCH mode = BATCH option.)*

- G** \_\_\_ **SP ACTIVATION** scrolls across the display and toggles with the current selection. Use the  and  buttons, select the relay activation to operate **ABOVE** or **BELOW** the setpoint value, and then press .



*Select **ABOVE** for the relay to turn on above the setpoint value and off below it. Select **BELOW** for the relay to turn on below the setpoint value and off above it.*

- H** \_\_\_ **HYSTERESIS VALUE** scrolls across the display and toggles with the current selection. Adjust this value using the  and  buttons, and then press .

*This defines the separation band between setpoint activation and deactivation, and will operate as per the type [set in 6.2J.]*

- I**  **If you set the HYSTERESIS VALUE to 0 in 6.2H:**

Skip step 6.2J and continue to 6.2K now.

- J** \_\_\_ **HYSTERESIS TYPE** scrolls across the display and toggles with the current selection. Use the  and  buttons to select **ALARM** or **CNTRL**. Press .

**ALARM** - Setpoint value controls setpoint activation point. Hysteresis value controls setpoint deactivation point.

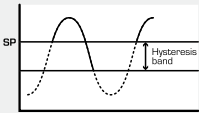

Energised Above

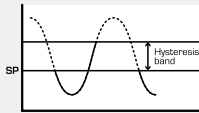

Energised Below

**CNTRL** - Setpoint value controls setpoint deactivation point. Hysteresis value controls setpoint reactivation point.

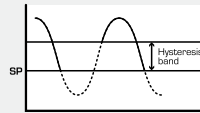

Energised Above

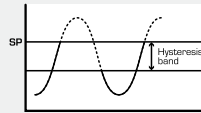

Energised Below

- K** \_ \_ \_ **MAKE DELAY** scrolls across the display and toggles with the current selection. Use the and buttons to adjust the make delay value (in tenths of a second) as required, and then press .

*The make delay value defines the delay between setpoint activation and when the relay turns on.*

- L** \_ \_ \_ **USER ACCESS?** scrolls across the display and toggles with the current access setting. Use the and buttons to select **NO** or **YES**, and press .

*Choosing **YES** will allow the selected setpoint to be quick-edited via the button without entering a PIN (see section B). User access can be independently configured for each setpoint.*

- M** \_ \_ \_ **EDIT SETPOINT** scrolls across the display and toggles with **SKIP**. You are now back at 6.2A. To edit another setpoint, follow the instructions from 6.2A-M again. If you do not wish to edit another setpoint, press now to **SKIP** to 6.3.

## 6.3 Edit setpoint PIN

- A** \_ \_ \_ **EDIT SP PIN** scrolls across the display and toggles with **SKIP**. Press to skip and return to the operational display, or the button and then to **ENTER**.

- B** \_ \_ \_ **ENTER NEW SP PIN** scrolls across the display and toggles with the current PIN (default 1). Using the and buttons, enter your new setpoint entry PIN number. Then press to save and **EXIT** to the operational display.

## 7 FACTORY ANALOGUE OUTPUT CAL

FACTORY ANALOGUE OUTPUT CALIBRATION IS PRECISELY SET BEFORE SHIPPING THIS INSTRUMENT. DO NOT ACCESS THIS FEATURE UNLESS INSTRUCTED BY THE MANUFACTURER. FOR ANALOGUE OUTPUT SCALING, SEE 5.6.

- A** Start with the controller powered off. Power up while holding the **F1** button.
- B** **\_\_\_ ENTER CAL PIN** scrolls across the display and toggles with **0**. Use the **▲** and **▼** buttons to enter your security code (factory default 1). Then press **P**. If the correct PIN is entered, continue to 7C.  
If an incorrect PIN is entered, **\_\_\_ ACCESS DENIED** scrolls across and it returns to the main display.  
*See section 9 if you have forgotten your PIN.*
- C** **\_\_\_ CALIBRATE ANALOG O/P?** scrolls across display and toggles with the current selection. Use the **▲** and **▼** buttons to select **YES** or **NO**, and then press **P**.
- D**  **If you selected NO in 7C:**  
Skip steps 7E-F and continue to 7G now.
- E** **\_\_\_ CAL LOW ANALOG O/P** scrolls across and toggles with the currently selected low scale value. Adjust this value using the **▲** and **▼** buttons, and then press **P**.
- F** **\_\_\_ CAL HIGH ANALOG O/P** scrolls across and toggles with the currently selected high scale value. Adjust this value using the **▲** and **▼** buttons, and then press **P**.
- G** Analogue output calibration is now complete. You will be directed to the operational display.



## 8 SETPOINT EASY ACCESS

EASY ACCESS IS CONFIGURED INDIVIDUALLY FOR EACH SETPOINT (SEE 6.2L). IF NONE OF THE SETPOINTS HAVE EASY ACCESS TURNED ON, THIS FEATURE WILL BE DISABLED AND THE **F2** BUTTON WILL NOT RESPOND TO A SHORT BUTTON PRESS.

- A Begin by pressing the **F2** button for less than 3 seconds. The setpoint name (**SP 1**, **SP 2**, **SP 3** or **SP 4**) will appear on the display and toggle with the current setpoint value. Using the **▲** and **▼** buttons, adjust the selected value. Then press **P** to accept the new setpoint value.
- B If any other setpoints have the direct access option enabled then the same process is repeated for the next setpoint. Pressing **P** for the last enabled setpoint will exit and return to the operational display.

## 9 RESET PIN NUMBERS

IF YOU HAVE FORGOTTEN YOUR PIN NUMBER(S), FOLLOW THE PROCEDURE BELOW TO RESET BOTH THE CALIBRATION AND SETPOINT SETUP PIN NUMBERS TO THEIR FACTORY DEFAULT OF 1.

- A Press ,  and  at the same time. (This key combination can be difficult to execute and you may need several tries to get it right.)
- B When successful, a factory identification text will scroll across the display, followed by: **\_\_\_ ALL PIN NUMBERS RESET TO 1.**
- C Reset the default PIN numbers if required by following the instructions in 5.8 (for setup and calibration) and 6.3 (for setpoint setup).

**A****APPENDIX A**

## Tare &amp; Batch Features

**A.1**

## Tare

To access tare features, the controller's weighing mode must be set to **NORMAL** (see 5.2E). It is then possible to tare/reset tare from the **(P)** button or rear input pins (see 5.2H-K and Appendix B).

**TARE** - This feature 'zeroes' the display, and is usually used to deduct the weight of the container from the total weight, leaving only the weight of the product.

**TARE RESET** - This feature clears the current tare value and show the gross weight on the display.

**A.2**

## Batch

To access batching features, the controller's weighing mode must be set to **BATCH** (see 5.2E). It is then possible to batch/reset batch from the **(P)** button or rear input pins (see 5.2H-K and Appendix B).

**BATCH** - This function is used to display the live weight of the system but take regular 'batches' of product without continually changing the setpoint. When the **BATCH** function is activated the display will tare and SP 1 and SP 2 will turn on.

**BATCH RESET** - This feature resets the batch value to zero and halts any current batching operations.

**BATCHING DIRECTION** - This parameter is set in 5.2G, and is based on whether product is being added to or discharged from the weighing system.

**NORMAL BATCHING (POSITIVE DIRECTION)** is when the weight increases as product is added to the weighing system. Set **BATCHING DIRECTION** to **POS** (see 5.2G).

*Eg. Setting a setpoint value of 50Kg for SP 1 and 5Kg for SP 2 and enabling batching mode (POS direction) will allow the user to fill a container to 50Kg with a potential speed change at 45Kg (50Kg – 5Kg).*

*The cycle is initiated when the **BATCH** function is triggered. The display will tare, and when 45Kg net weight is shown, SP 2 will drop out. If product continues to feed, at 50Kg SP1 will drop out, halting the fill.*

*If **FLASH GROSS** is enabled (see 5.2L) the gross weight will be displayed (Eg. Now 1050Kg, if the starting gross weight was 1000Kg). The user can then trigger the **BATCH** function again to call another 50kg batch.*

**LOSS IN WEIGHT BATCHING (NEGATIVE DIRECTION)** is when the weight decreases as product is removed from the weighing system. Set **BATCHING DIRECTION** to **NEG** (see 5.2G).

*Eg. Setting a setpoint value of 50Kg for SP 1 and 5Kg for SP 2 and enabling batching mode (NEG direction) will allow the user to fill a container to 50Kg with a potential speed change at 45Kg (50Kg – 5Kg).*

*The cycle is initiated when the **BATCH** function is triggered. The display will tare, and when 45Kg net weight is discharged, SP 2 will drop out. If product continues to be discharged, at 50Kg SP1 will drop out, halting the product flow.*

*If **FLASH GROSS** is enabled (see 5.2L) the gross weight will be displayed (Eg. Now 950Kg, if the starting gross weight was 1000Kg). The user can then trigger the **BATCH** function again to call another 50kg batch.*

*In this mode if there is not enough product to drop a batch then the instrument will advise the operator by showing the message **LOW PRODUCT**.*

*If **gross** > **SP1**, the batch value is reset to zero and the display flashes **BATCH**. SP1 is turned on (and SP2 if set up). If **gross** < **SP1**, batching is not started.*

## B

APPENDIX B  
Input Functions

A number of user programmable functions are accessible from the **P** button and rear pins (see 5.2H-K). Note that availability of the **TARE/BATCH** feature is subject to your selection in 5.2E.

## KEY

- P** Continuous press
- P**<sup>1/2</sup> Short press (1/2 sec)
- P**<sup>2+</sup> Long press (2+ sec)
- Continuous pin activation
- <sup>1/2</sup> Short pin activation (1/2 sec)
- <sup>2+</sup> Long pin activation (2+ sec)

- HOLD** **P** → Freezes the display value.
- LOCK** → Locks the control panel.
- TARE** **P**<sup>1/2</sup> →<sup>1/2</sup> Tares display value (flashes **TARE**).  
**P**<sup>2+</sup> →<sup>2+</sup> Resets tare to zero (flashes **TR RST** and then shows gross).
- BATCH** **P**<sup>1/2</sup> →<sup>1/2</sup> Performs a batch operation. (See Appendix A.)  
*If a batch is already in progress, no function will be performed. If you have just powered up following a power loss during batching, the controller will RESUME without resetting the batch value.*
- P**<sup>2+</sup> →<sup>2+</sup> Resets the batch value to zero and flashes **BT RST**. Any current batching operations will be halted.
- ZERO** **P**<sup>1/2</sup> →<sup>1/2</sup> Zeroes the weight if the zero offset (i.e. the difference between the current no load weight and the calibration no load value) is within the **ZERO BAND**. (See Appendix C.)  
*If the offset is less than the limit set in ZERO BAND (see 5.4F), the zero value is updated and the display flashes ZERO. If the offset is greater than the limit set in ZERO BAND (see 5.4F), the zero value is not updated and the display scrolls OUTSIDE OF ZERO BAND!*
- P**<sup>2+</sup> →<sup>2+</sup> Resets the zero offset value to the original calibration offset value. Display flashes **RS ZER** and then shows gross.
- PEAK** **P**<sup>1/2</sup> Displays the peak value for 2 seconds.  
**P**<sup>2+</sup> Sets the peak value to the current input value (flashes **PK RST**).  
 → Displays the peak value continuously.
- PK RST** **P** → Sets the peak value to the current input value (flashes **PK RST**).
- PRINT** **P** → Sends a single Ranger A output string.  
*SERIAL MODE must be set to RNGR A (see 5.7B), and RANGER OUTPUT MODE must be set to PULSED (see 5.7E).*

## C

APPENDIX C  
Zero Maintenance

The zero maintenance feature is used to automatically compensate for slow drift in loadcell output due to factors such as temperature change, rain and dust accumulation over time. The controller display will zero automatically, provided that changes to the loadcell remain within the user specified **CAPTURE BAND**, **MOTION BAND** and **ZERO BAND** parameters (see 5.4D-F).

**CAPTURE BAND** (5.4D) - This is the maximum number of display counts that the controller will automatically zero within. The **CAPTURE BAND** is referenced to the current zero value. If the input value on the load cell is not within the **CAPTURE BAND** setting then the controller displays the current loadcell value and does not zero.

*CAPTURE BAND can be set from 1 to 254 counts, and should always be set to less than the smallest weight to be measured. Setting the CAPTURE BAND to 0 will turn the auto zero feature off.*

**MOTION BAND** (5.4E) - This provides a rate of change limit setting, to determine the number of counts/second allowed within the **CAPTURE BAND**. If the count change is within the **CAPTURE BAND**, but the speed of the count change is more than the selected **MOTION BAND**, then the controller displays the current loadcell value and does not zero.

*The MOTION BAND can be set from 0 to 255 counts. Typical value is 1 or 2 counts/sec.*

**ZERO BAND** (5.4F) - This provides a limit for the number of counts of zero offset allowed to accumulate, relative to the calibrated zero setting. If the accumulated zero offset becomes greater than this window, then the controller displays the current loadcell value and does not zero.

*The suggested limit for the ZERO BAND is 2% of the calibrated span. If the controller fails to zero, check for mechanical or electrical faults.*

## D

APPENDIX D  
Serial Modes

## D.1

## Custom ASCII

Custom ASCII is a simple, custom protocol that allows connection to various PC configuration tools. (Please note that the 'Custom ASCII' protocol differs from the 'Modbus (ASCII)' protocol used by some devices.) Custom ASCII command strings must be constructed in this order:

**<Start> <Controller Address> <Read/Write Command> <Register Address>  
<Separator Character> <Data Value> <Message Terminator>**

**START** - Use 'S' for the start character of a command string (not case sensitive). This must be the first character in the string.

**CONTROLLER ADDRESS** - Use an ASCII number from '1' to '255' for the controller address. If the character following the start character is not an ASCII number, then address '0' is assumed. All controllers respond to address '0'.

**READ/WRITE COMMAND** - Use ASCII 'R' for read, 'U' for unformatted read, or 'W' for write (not case sensitive). Any other character aborts the operation.

*In Custom ASCII mode, data is normally read as formatted data (which includes decimals and any text characters that may be selected to show units). However it is also possible to read unformatted data by using a 'U' in the read command. There is no unformatted write command, as when writing to fixed point registers, any decimal point and text characters are ignored.*

**REGISTER ADDRESS** - The register address for the read/write operation will be an ASCII number from '1' to '65535'. This character must be specified for a write command, but may be omitted for a read command, (in which case the controller will respond with the data value currently on the display).

**SEPARATOR CHARACTER** - The separator character can be either a space or a comma, and is used to separate the register address from the data value.

**DATA VALUE** - This must be an ASCII number. The absolute limits for this number are **-1000000** to **1000000**, but it should be noted that not all registers will accept this range.

**MESSAGE TERMINATOR** - This is the last character, and must be either a '\$' (dollar) or an '\*' (asterisk). Neither of these characters should be used elsewhere in the message string. If '\$' is used, a 50ms minimum delay is inserted before a reply is sent. If '\*' is used, a 2ms minimum delay is inserted before a reply is sent.

### CUSTOM ASCII READ/WRITE EXAMPLES

Example	Description
<b>SR\$</b>	Read display value from all controllers, 50ms delay.
<b>S15R\$</b>	Read display value from controller address 15, 50ms delay.
<b>S3U40*</b>	Read unformatted data in channel 4 from controller address 3, 2ms delay.
<b>S2W2-10000\$</b>	Write -10000 to the display register of controller address 2, 50ms delay.
<b>SWT Chan_1\$</b>	Write ASCII text string Chan_1 to channel 1 text register, 50ms delay.

### CUSTOM ASCII REGISTERS

16-BIT UNSIGNED	
Address	Function
<b>1</b>	Alarm status (Bit 0=SP1, Bit 1=SP2, Bit 2=SP3, Bit 3=SP4)
<b>65</b>	Hysteresis SP1
<b>71</b>	Make delay SP1
<b>66</b>	Hysteresis SP2
<b>72</b>	Make delay SP2
<b>67</b>	Hysteresis SP3
<b>73</b>	Make delay SP3
<b>68</b>	Hysteresis SP4
<b>74</b>	Make delay SP4

32-BIT SIGNED	
Address	Function
<b>3</b>	Tared/Batch weight (net)
<b>4</b>	mV
<b>39</b>	Live weight (gross)
<b>16</b>	Tare value
<b>12</b>	Peak
<b>13</b>	Valley
<b>6</b>	Setpoint 1
<b>7</b>	Setpoint 2
<b>8</b>	Setpoint 3
<b>9</b>	Setpoint 4
<b>34</b>	D/A scale low value
<b>36</b>	D/A scale high value

**CONTROLLER RESPONSE** - After the controller has completed a read or write instruction, it responds by sending a carriage return/line feed (CR/LF) back to the host. If the instruction was a read command, the CR/LF follows the last character in the ASCII string. If it was a write command, a CR/LF is the only response sent back to the host. The host must wait for this before sending any further commands to the controller. If the controller encounters an error while trying to access a register, it will respond with a null (0x00) CR/LF.

## D.2 Modbus (RTU)

Modbus (RTU) is an industry standard RTU slave mode that allows connection to a wide range of devices, such as PC's or PLC's. Modbus registers are all holding registers, and should be accessed via function codes 3 and 6. Register addresses are displayed in the Modicon™ addressing format. i.e. Register 65=40065 (subtract 1 for direct addressing).

### MODBUS (RTU) REGISTERS

16-BIT UNSIGNED		32-BIT SIGNED (2x16-bit)		
Address	Function	LSW	MSW	Function
40001	Alarm status (Bit 0=SP1, Bit 1=SP2, Bit 2 =SP3, Bit 3=SP4)	40515	40516	Tared/Batch weight (net)
40065	Hysteresis SP1	40517	40518	mV
40071	Make delay SP1	40521	40522	Live weight (gross)
40066	Hysteresis SP2	40529	40530	Tare value
40072	Make delay SP2	40525	40526	Peak
40067	Hysteresis SP3	40527	40528	Valley
40073	Make delay SP3	40535	40536	Setpoint 1
40068	Hysteresis SP4	40537	40538	Setpoint 2
40074	Make delay SP4	40539	40540	Setpoint 3
		40541	40542	Setpoint 4
		40587	40588	D/A scale low value
		40591	40592	D/A scale high value

**D.3** Ranger A

Ranger A is a continuous output, used to drive remote displays and other instruments in the Rinstrum™ range. (Ranger is a tradename belonging to Rinstrum Pty Ltd.)

Ranger A output strings are constructed as shown:

**<Start> <Sign> <Output Value> <Status> <End>**

**START** - STX character (ASCII 02)

**SIGN** - Output value sign (space for + and dash for -)

**OUTPUT VALUE** - Seven character ASCII string containing the current output value and decimal point. (If there is no decimal point, then the first character is a space. Leading zero blanking applies.)

**STATUS** - Single character output value status. 'U'=Under, 'O'=Over, 'E'=Error.

**END** - ETX character (ASCII 03)





---

**Texmate NZ Ltd.**

10B Vega Place, Mairangi Bay  
North Shore City 0632, New Zealand

**Ph:** +64 (9) 835-1550

**Aus:** 1800 810-820

**Fax:** +64 (9) 835-1250

**Web:** [www.texmate.co.nz](http://www.texmate.co.nz)



***PRO-WE100***

**DOCUMENT REVISION CODE:  
PRO-WE100-MAN-10-V.01**