



COUNTER CONTROLLER

**SC - CTR Setup Manual
(R2/R2A/R2S/R2AS)**

CONTENTS

Introduction	1
Specifications	2
Case Diagrams	4
Wiring	8
Setup & Calibration	16
Setpoint Setup	34
Setpoint Direct Access	45

APPENDICES

A - Reset PIN Numbers	46
B - Display Shortcuts	47
C - Primary & B Input Count Modes	48
D - C Input Count Modes	53

1 INTRODUCTION

SC controllers interface smoothly with a wide range of PLC and monitoring systems. These sophisticated instruments are designed to relieve the PLC of processing overhead, reducing costs and extending the capability of the total system.

The SC - CTR has been designed for ease of use. It has a built-in LCD display and five front-panel buttons for simple operator interface. The slim case is 35mm DIN-rail compatible, ensuring hassle-free mounting. This controller has been design specifically for use in counter applications, and comes factory pre-calibrated to suit either a 0-20mA or a 4-20mA input. It's also easy to setup (or re-calibrate) with on-screen, step-by-step instructions.

The SC - CTR is available as a standard R2 model, and can also be purchased with the addition of an analog output (R2A), a serial port (R2S), or both (R2AS).

2 SPECIFICATIONS

Input	3 independent hardware counters
Power supply	HV 85-265V AC/95-370V DC or LV 15-48V AC/10-72V DC
Relay outputs	2 programmable form A relays with volumetric pulse option. (3A 240V AC max or 3A 30V DC max.)

OPTIONAL OUTPUTS

Analog output	Isolated 16-bit 4-20mA/0-10V output [fully scaleable]. Window programmable over any range within the full-scale range of the controller
Serial port	Isolated RS232 or RS485 <i>Modes:</i> Texmate ASCII, Modbus RTU slave, Ranger A output. <i>Data rates:</i> 300-38400. Odd, even or no parity.

Easy setup	Intuitive text prompts, for easy setup.
Security	Calibration and setpoint functions have independent security code access, and direct access to setpoint activation values is independently configurable.
Excitation	24V input excitation supplied
Input header	Default NPN (open collector). Can be factory configured for mV/TTL/PNP
Count modes	Quad [x1, x2 or x4], A+B, A-B, A/B Indp, Up/Down, C counter (control to capture, reset, zero and/or restart A & B counters), A+B+C
Input frequency	10kHz (Quad x4, A+B, A-B, A/B Ind, Up/Down, RSOFAB, RSOFST) 20kHz (Quad x1, Quad x2) 38kHz (C Count)
Frequency	100kHz on A input
Case	101 x 45 x 119.5mm (H x W x D)

3 CASE DIAGRAMS

Fig 1 - Front View



BUTTON PRESS FUNCTIONS

- ① **Program** - This button is typically used to save your settings and advance to the next step in the setup process.

- ② **Up** - This button is typically used to scroll through options or increase values in the setup menu.
.....
Pressing this button from the operational display will allow you to view and/or reset the peak value, and also view the rate and primary counter values. See Appendix B [p47].

- ③ **Down** - This button is typically used to scroll through options or decrease values in the setup menu.
.....
Pressing this button from the operational display will allow you to view and/or reset the valley value, and also view the B and C counter values. See Appendix B [p47].

- ④ **Function 1** - This button is used to access the input setup and calibration menu. See Section 5.

- ⑤ **Function 2** - This button is used to access the setpoint setup menu (see Section 6) and the setpoint direct access menu (see Section 7).

Fig 2 - Top View

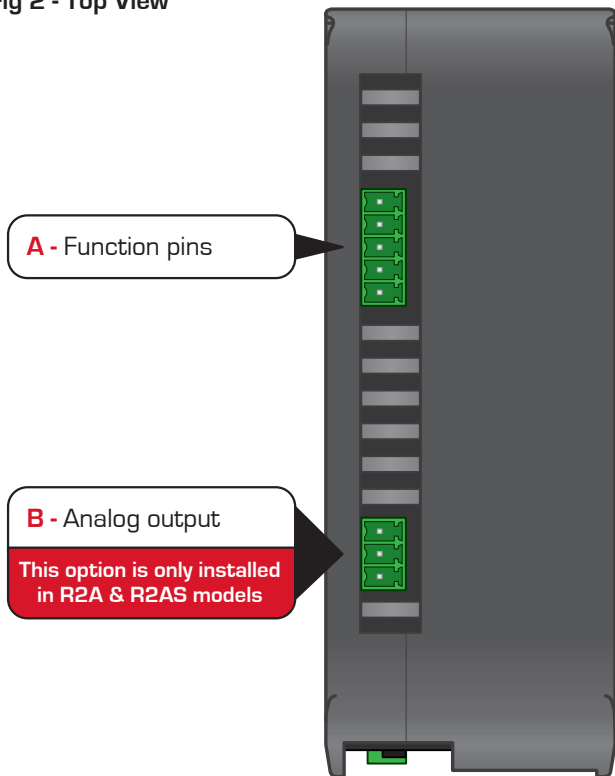
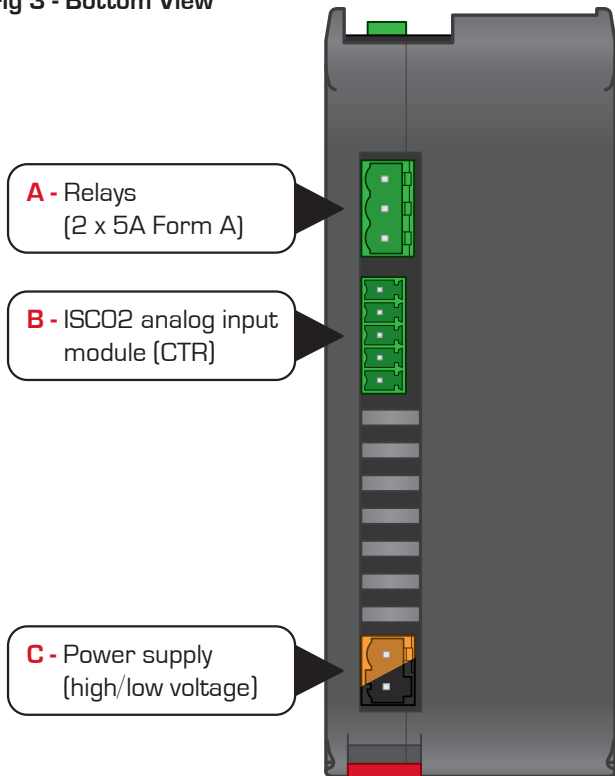

Fig 3 - Bottom View



4

WIRING

Before you begin:

Determine whether your controller is configured for low or high voltage power supply. Make sure to check the label on the unit against the colour of the power connector:

- **Black** = low voltage
- **Orange** = high voltage

4.1 Connect your SC - CTR to the power supply

Refer to Section 3, Fig 3C

Wire your controller to your power supply as per the appropriate diagram below.

Remember to switch your power supply off before you begin wiring, and NEVER connect your low voltage controller to mains power.

Low voltage (LV) - 15-48V AC, 10-72V DC

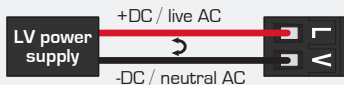

High voltage (HV) - 5-265V AC, 95-370V DC

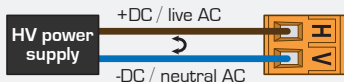

4.2 Wire your ISCO2 analog input module

Refer to Section 3, Fig 3B

The ISCO2 input module has eight headers which are factory configured to suit your application when you place your order.

If you choose not to specify your input settings when you order your SC - CTR, the module will be set to the factory defaults show below: NPN input for all channels and 24V excitation.

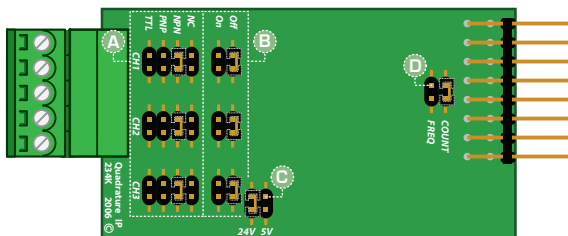

INPUT TYPE

Ⓐ

For inputs A [CH 1], B [CH 2] & C [CH 3]

NC	Not connected	NPN
PNP		TTL

NOISE FILTERING

Ⓑ

For inputs A [CH 1], B [CH 2] & C [CH 3]

Off	For high-speed encoding	On	1kHz low-pass filter, for noisy signal or mechanical contact
------------	-------------------------	-----------	--

EXCITATION VOLTAGE

Ⓒ

24V	Standard setting	5V	May apply to some encoders
------------	------------------	-----------	----------------------------

MODE

Ⓓ

COUNT	ALWAYS use this setting	FREQ	NEVER used for SC - CTR
--------------	-------------------------	-------------	-------------------------

The diagram below shows the wiring for non-quadrature sensors. For quadrature encoders, see p13.

Non-Quadrature Sensor Connections

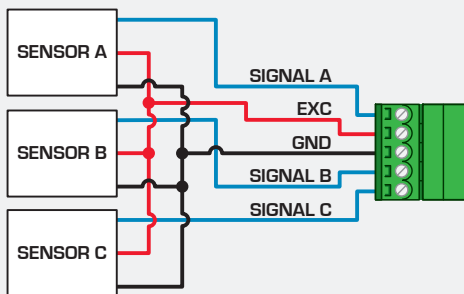

Multiple sensors can be connected. Any combination of the following can be used for sensors A, B or C above:

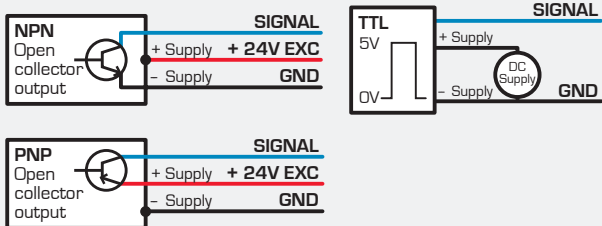

Quadrature Encoder

(Speed & direction)

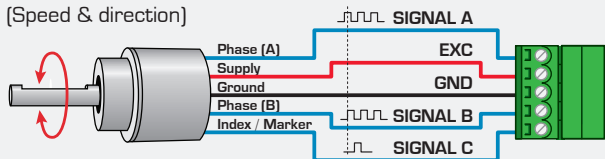
**4.3** Wire your analog output (if fitted)*Refer to Section 3, Fig 2B*

If your SC is an R2A or R2AS model, wire your analog output as shown.



4.4 Wire your relays (if required)

Refer to Section 3, Fig 3A

Your SC - CTR has two 5A form A relays and two setpoints.

These can be individually programmed to operate within the total span range of the controller. (See 6.2 for SP 1, and 6.3 for SP 2.)

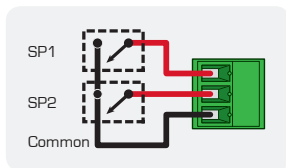

4.5 Wire your serial port (if active)

Refer to Section 3, Fig 1A

If your SC is an R2AS model, then your controller's front panel serial port is active, and should be wired as shown.



R2 and R2A models have an INACTIVE serial connector on the front panel.

4.6 Wire your function pins (if required)

Refer to Section 3, Fig 2A

The following functions can be performed:

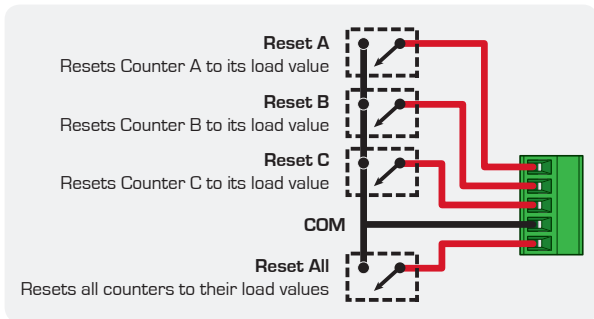

4.7 Power up your controller

Once you have completed the wiring process it is safe to switch on your power supply. Ensure that your display is functioning before you proceed.

5 SETUP & CALIBRATION

Enter the calibration mode by pressing **F1**.

5.1 Enter calibration PIN

A **_ _ _ ENTER CAL PIN NUMBER** scrolls across the bottom row and **0** appears in the top row. Use the **▲** and **▼** buttons to enter your security code (factory default 1). Then press **P**. If the correct PIN is entered then the setup is started at 5.2.

If an incorrect PIN number is entered, **_ _ _ INCORRECT PIN NUMBER - ACCESS DENIED** scrolls across the display and it returns to the normal operating mode.

You will be given the opportunity to change your PIN number at the end of this section (5.7). If you have forgotten your PIN number, see Appendix A (p46).

5.2 Enter calibration PIN

There are 3 counter inputs available on the input module - count inputs A, B & C. When the primary counter mode is set to **AB IND** (A & B independent), the A input drives the primary counter and the B input drives the secondary counter.

In other count modes the A & B inputs are both used to drive the primary counter, so the B counter options are not available. It is therefore advisable to set up the primary count mode first.

A ___ **COUNTER SETUP** scrolls across the bottom row and **Skip** appears in the top row. Press **(P)** to skip to 5.3, or use the **(▲)** and **(▼)** buttons to select: **Prm Cntr** (Primary counter), **Sec Cntr** (Secondary counter) or **C Input** (C Input pin).



*The secondary counter cannot be independently configured unless the primary count mode is set to **A/B Indp** (see 5.2B). Attempts to enter secondary (**B INPT**) counter setup when the above condition has not been met will redirect you to the counter setup menu (5.2A) and display the following error message:*

___ NOT AVAILABLE! - CHANGE PRIMARY COUNT MODE

▶▶ More info on count modes ▶▶ See Appendices C-D (p48-54)



If you selected **Prm Cntr** in 5.2A:

- B** ___ **COUNT MODE** scrolls across the bottom row and the currently selected count mode appears in the top row. Using the  and  buttons, select: **Quad x1**, **Quad x2**, **Quad x4**, **A+B**, **A-B**, **A/B Indp**, or **Up/Dn**. Then press .

See Appendix C (p48) for more information.





If you selected **Sec Cntr** in 5.2A:



- B** Skip 5.2B and continue to 5.2C now.









If you selected **C Input** in 5.2A:

- B** ___ **COUNT MODE** scrolls across the bottom row and the current count mode appears in the top row. Using the  and  buttons, select: **Count**, **RsOf A/B** or **RsOfStAB**. Then press .



See Appendix D (p53) for more information.

C ___ **DECIMAL POINT POSITION** scrolls across the bottom row and the currently selected decimal point position appears in the top row. Using the  and  buttons, select either: **No DP**, **0.1**, **0.12**, **0.123**, **0.1234**, or **0.12345**, and then press .

D ___ **PULSES PER UNIT OF MEASUREMENT** scrolls across the bottom row and the currently selected number of pulses appears in the top row. Use the  and  buttons to adjust your number of pulses, and then press .

E ___ **ENTER DISPLAY VALUE FOR (X) PULSES** scrolls across the bottom row and the current display value appears in the top row. Adjust this value as required using the  and  buttons, and then press .



For example, if you selected 1,500 pulses in 6.2D, and 1,500 pulses = 1 metre, then enter 1 here. (Enter this value with reference to your decimal point position - the controller will automatically calculate the correct scale factor for you.)

- F** ___ **RESET AT POWER UP** scrolls across the bottom row and the current setting appears in the top row. Use the  and  buttons to select either **No**, **Zero** or **Ld Val** (load value). Then press .

No - The count value will be retained at power up.

Zero - The count value will be cleared to zero at power up.

Ld Val (load value) - The count value will be set to a user defined load value at power up (see 5.2G).

- G** ___ **LOAD VALUE** scrolls across the bottom row and the currently selected load value appears in the top row. Use the  and  buttons to adjust your load value as desired. Then press .

*This value is loaded into the counters at power up when **Ld Val** is selected in 5.2F above. It is also the value used for the C input reset functions **RsOf A/B** and **RsOfStAB** (see Appendix D (p53).)*

- H** ___ **COUNTER SETUP** scrolls across the bottom row and **Skip** appears in the top row.

You are now back at 5.2A. To set up another input channel, repeat the instructions from 5.2A-G. If you have finished, press  now to proceed to 5.3.

5.3 Rate display setup



- A** ___ **RATE DISPLAY SETUP** scrolls across the bottom row and **Skip** appears in the top row. Press **P** to skip to 5.4, or the **▲** button and then **P** to **Enter** setup.

The rate value is taken from the primary count input (signal A).

- B** ___ **DECIMAL POINT POSITION** scrolls across the bottom row and the currently selected decimal point position appears in the top row. Using the **▲** and **▼** buttons, select either: **No DP**, **0.1**, **0.12**, **0.123**, **0.1234**, or **0.12345**, and then press **P**.



- C** ___ **ROUNDING** scrolls across the bottom row and the currently selected rounding appears in the top row. Using the **▲** and **▼** buttons, select either: **None**, **2**, **5** or **10**. Then press **P**.

Rounding is quoted in display counts and is not influenced by decimal point position. For example, if your input signal is 5.3, the display will show: 5.3 (for rounding=None), 5.4 (for rounding=2), 5.5 (for rounding=5) or 5.0 (for rounding=10).



- D** ___ TIME PERIOD FOR RATE DISPLAY scrolls across the bottom row and the currently selected time period appears in the top row. Using the  and  buttons, select: **Seconds, Minutes** or **Hours**. Then press .

This parameter allows you to view the effective rate over different time periods. For example, if the measurement units are metres, then rate can be viewed in m/sec, m/min or m/hr.

The SC - CTR will automatically calculate the required scaling factors based on the input channel setup, so you must complete Section 5.2 first.

- E** _ _ _ RATE MULTIPLIER scrolls across the bottom row and the currently selected multiplication factor appears in the top row. Using the  and  buttons, select: **x0.0001, x0.001, x0.01, x0.1, x1, x10, x100,** or **x1000**. Then press .

This option allows the user add a scale factor to the rate display calculation, to display the value in the required units.

- F** _ _ _ LOW CUT scrolls across the bottom row and the current selection appears in the top row. Adjust as required using the  and  buttons, and press .

When the rate drops below the low cut value, it displays as zero.

- G** ___ **DISPLAY ZERO TIME** scrolls across the bottom row and the current display zero time appears in the top row. Use the **▲** and **▼** buttons to select either: **0.5sec** or **100sec**, and then press **P**.

The display zero time controls how quickly the rate display changes to zero. Select 100 seconds for slow inputs, and 0.5 seconds for faster inputs [more than 2 pulses/second].

Averaging (5.3H-I)

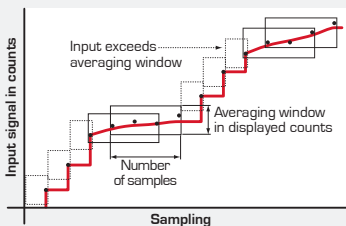

Input signal averaging on the rate guarantees stable measurement.

If the input exceeds the averaging window value it will not average, ensuring fast response.



- H** ___ **AVERAGE SAMPLES** scrolls across the bottom row and the currently selected averaging appears in the top row. Using the **▲** and **▼** buttons, alter the number of rate samples that the controller will average. Press **P**.

Increasing the number of samples will stabilise measurement, but it will also slow down response rates.

- I **___ AVE WINDOW** scrolls across the bottom row and the currently selected averaging window value appears in the top row. Using the  and  buttons, alter the signal averaging window. Then press .

If your input signal contains large noise spikes, then you can increase the size of averaging window to ensure that these pulses are still averaged. However, increasing the averaging window too far will reduce the ability of the controller to respond quickly to real changes in input signal.

Setting the averaging window to zero will turn off the window mode and give continuous averaging as per the selected averaging samples.

5.4 Display setup

- A** _ _ _ **DISPLAY SETUP** scrolls across the bottom row and **Skip** appears in the top row. Press **P** to skip to 5.5, or the **▲** button and then **P** to **Enter** display setup.
- B** _ _ _ **LINE 1 DISPLAY SOURCE** scrolls across the bottom row and the currently selected line 1 (top row) display source appears in the top row. Using the **▲** and **▼** buttons, select: **None**, **Prm Cntr**, **B Cntr**, **C Cntr**, **Rate**, or **A+B+C**. Then press **P**.
- C** _ _ _ **LINE 2 DISPLAY SOURCE** scrolls across the bottom row and the currently selected line 2 (bottom row) display source appears in the top row. Using the **▲** and **▼** buttons, select: **None**, **Prm Cntr**, **B Cntr**, **C Cntr**, **Rate**, or **A+B+C**. Then press **P**.

5.5

Analog output setup (R2/R2S users skip this step)

Please note that R2/R2S models do not have this option installed - these instructions are only relevant to R2A/R2AS users.



A **___ ANALOG OUTPUT SETUP** scrolls across the bottom row and **Skip** appears in the top row. Press **[P]** to skip to 5.6, or the **[▲]** button and then **[P]** to **Enter** analog output setup.

B **___ DATA SOURCE FOR ANALOG OUTPUT** scrolls across the bottom row and the currently selected data source appears in the top row. Using the **[▲]** and **[▼]** buttons, select: **None**, **Prm Cntr**, **B Cntr**, **C Cntr**, **Rate** or **A+B+C** (total), and then press **[P]**.

C **___ LOW SCALE VALUE FOR ANALOG OUTPUT** scrolls across the bottom row and the currently selected low scale value appears in the top row. Use the **[▲]** and **[▼]** buttons to set the low scale value. Then press **[P]**.

This sets the display value for cal low (as at 5.5F).

D _ _ _ HIGH SCALE VALUE FOR ANALOG OUTPUT



scrolls across the bottom row and the currently selected high scale value appears in the top row. Use the  and  buttons to set the high scale value. Then press .

This sets the display value for cal high (as at 5.5F).

E _ _ _ CALIBRATE ANALOG OUTPUT?

scrolls across the display and toggles with **Skip**. If you do not wish to calibrate your analog output, press  now.

If you would like to calibrate your analog output:

Connect a mA or volt meter across the analog output connector (see Section 4.3). Press the  button to select **Enter**, and then press  to enter calibration mode.





If you selected SKIP in 5.5E:



F Skip the rest of this section and continue to 5.6.



If you selected ENTER in 5.5E:

F _ _ _ **CALIBRATE LOW** scrolls across the bottom row and a calibration number appears in the top row. Using the  and  buttons, calibrate your low analog output as required. Then press .

The display value is shown in internal units [mA].

_ _ _ **CALIBRATE HIGH** scrolls across the bottom row and a calibration number appears in the top row. Using the  and  buttons, calibrate your high analog output as required. Press .

The display value is shown in internal units [mA].

5.6 Serial setup (R2/R2A users skip this step)

Please note that R2/R2A models do not have an active serial port - these instructions are only relevant to R2S/R2AS users. Configuring an active serial port on your SC - CTR (as specified below) will allow you to connect your controller to a PC or another device.

A _ _ _ **SERIAL SETUP** scrolls across the bottom row and **Skip** appears in the top row. Press **P** to skip to 5.7, or the **▲** button and then **P** to **Enter** serial setup.

B _ _ _ **SERIAL MODE** scrolls across the bottom row and the currently selected serial mode appears in the top row. Using the **▲** and **▼** buttons, select either: **ASCII, Modbus (RTU)** or **Ranger A**. Then press **P**.

*Texmate **ASCII** is a simple protocol that allows connection to various Texmate PC configuration tools.*

***Modbus** is an industry standard RTU slave mode that allows connection to a wide range of devices, such as PC's or PLC's.*

***Ranger A** is a continuous output, used to drive remote displays and other instruments in the Rinstrum™ range. (Ranger is a trade name belonging to Rinstrum Pty Ltd.)*









If you selected ASCII or Modbus in 5.6B:



- C** Skip step 5.6C and continue to 5.6D now.





If you selected Ranger A in 5.6B:

- C** _ _ _ **SERIAL DATA SOURCE** scrolls across the bottom row and the currently selected Ranger A serial data source appears in the top row. Use the  and  buttons to select: **Prm Cntr, B Cntr, C Cntr, Rate** or **A+B+C**. Then press .

- D** _ _ _ **BAUD RATE** scrolls across the bottom row and the current selection appears in the top row. Using the  and  buttons, select: **300, 600, 1200, 2400, 4800, 9600, 19200** or **38400**. Then press .

- E** _ _ _ **PARITY** scrolls across the bottom row and the current selection appears in the top row. Using the  and  buttons, select either: **None, Odd** or **Even**. Then press .

- F** _ _ _ **SERIAL ADDRESS** scrolls across the bottom row and the currently selected serial address appears in the top row. Use the  and  buttons to alter the serial address. Then press .

The serial address parameter is used to identify a particular device when it is used with other devices in a system. [It applies particularly to Modbus mode when used on a RS485 network.] The serial address of the controller must be set to match the serial address defined in the master device.

▶▶ More info on registers ▶▶

See tables [below, p32]

RANGER A - This allows the controller to drive a remote display from the Rinstrum range. The following shows the output string format when Ranger A output is selected:

<Start> <Sign> <Output Value> <Status> <End>

STRING CHARACTER(S)	
<Start>	STX character [ASCII 02]
<Sign>	Output value sign (space for + and dash for -)
<Output Value>	Seven character ASCII string containing the current output value and decimal point. <i>[If there is no decimal point, then the first character is a space. Leading zero blanking applies.]</i>
<Status>	Single character output value status: U=Under, O=Over, E=Error
<End>	ETX character [ASCII 03]

MODBUS REGISTERS - These are all holding registers and should be accessed via function codes 3 and 6.

Register addresses are displayed in the Modicon™ addressing format. i.e. Register 65=40065 (subtract 1 for direct addressing).

16-BIT SIGNED	
Address	Function
40001	Alarm status (Bit 0= SP 1, Bit 1=SP 2)
40071	Make delay SP 1
40072	Make delay SP 2
40077	Break delay SP 1
40078	Break delay SP 2

32-BIT SIGNED (2x16-bit)	
LSW / MSW	Function
40513 / 40514	Process display
40517 / 40518	Rate
40519 / 40520	C count
40521 / 40522	Primary count
40523 / 40524	B count
40525 / 40526	Peak
40527 / 40528	Valley
40529 / 40530	A + B + C count
40535 / 40536	Setpoint 1
40537 / 40538	Setpoint 2
40587 / 40588	D/A scale low value
40591 / 40592	D/A scale high value

5.7 Edit calibration PIN

- A** _ _ _ **EDIT CAL PIN NUMBER** scrolls across the bottom row and **Skip** appears in the top row. Press **P** to skip and return to the operational display, or the **▲** button and then **P** to **Enter**.
- B** _ _ _ **ENTER NEW CAL PIN NUMBER** scrolls across the bottom row and the current PIN (default 1) appears in the top row. Using the **▲** and **▼** buttons, enter your new calibration PIN number. Then press **P** to **Exit** and return to the operational display.

6 SETPOINT SETUP

Enter the setpoint setup mode by pressing and holding the **F2** button for 3 seconds.

6.1 Enter setpoint PIN

A **_ _ _ ENTER SP PIN** scrolls across the bottom row and **0** appears in the top row. Use the **▲** and **▼** buttons to enter your security code (factory default 1). Then press **P**. If the correct PIN is entered then the setup is started at 6.2.

If an incorrect PIN number is entered, **_ _ _ INCORRECT PIN NUMBER - ACCESS DENIED** scrolls across the display and it returns to the normal operating mode.

You will be given the opportunity to change your PIN number at the end of this section (6.4). If you have forgotten your PIN number, see Appendix A (p46).

6.2 Edit setpoint 1

- A** **__ _ EDIT SETPOINT** scrolls across the bottom row and **Skip** appears in the top row. Press **[P]** to skip to 6.4 [two sections ahead in this manual!] or use the **[▲]** and **[▼]** buttons to select **SP 1**. Then press **[P]**.

SP 2 will also be available from this menu. If you would like to edit SP2, please skip this section and follow the instructions in Section 6.3.



- B** **__ _ SP VALUE** scrolls across the bottom row and the last setpoint value entered appears in the top row. Using the **[▲]** and **[▼]** buttons, adjust the display value at which the setpoint will activate. Then press **[P]**.

- C** **__ _ VOLUMETRIC PULSE** scrolls across the bottom row and the current setting appears in the top row. Use the **[▲]** and **[▼]** buttons to select **Off** or **On**. Press **[P]**.



When the selected setpoint is activated in volumetric pulse mode, the primary counter will reset to 0 and then resume counting. The selected relay will activate for the pulse time specified in 6.2D.





If you selected **Off** in 6.2C:

D ___ **SP ACTIVATION** scrolls across the bottom row and the last selected setpoint activation appears in the top row. Using the  and  buttons, select the relay activation to operate **Above** or **Below** the setpoint value, and then press .



*Select **Above** for the relay to turn on above the setpoint value and off below it. Select **Below** for the relay to turn on below the setpoint value and off above it.*

___ **MAKE DELAY** scrolls across the bottom row and the current selection appears in the top row. Adjust using the  and  buttons, and press .

This defines the delay between setpoint activation and when the relay turns on. This value is in tenths of a second.



___ **BREAK DELAY** scrolls across the bottom row and the current selection appears in the top row. Adjust using the  and  buttons, and press .

This defines the delay between setpoint de-activation and when the relay turns off. This value is in tenths of a second.



___ **SETPOINT SOURCE** scrolls across the bottom row and the currently selected setpoint source appears in the top row. Using the  and  buttons, select: **Prm Cntr**, **B Cntr**, **C Cntr**, **Rate** or **A+B+C**. Then press .







If you selected On in 6.2C:

D ___ **PULSE TIME** scrolls across the display and toggles with the currently selected pulse time. Use the  and  buttons to select your pulse time (from 0.1 to 10.0 seconds), and then press .

Pulse reset requires a minimum of 0.1 seconds. A combination of high input rates and low setpoint values may exceed this limitation, resulting in missed output pulses.

___ **SETPOINT SOURCE** scrolls across the bottom row and the currently selected setpoint source appears in the top row. Using the  and  buttons, select: **Prm Cntr**, **B Cntr** or **C Cntr**. Then press .

- E** **___ USER ACCESS?** scrolls across the bottom row and the last selected direct access setting appears in the top row. Using the  and  buttons, select either **Off** or **On**. Then press .

When enabled, this option allows the setpoint value to be edited directly after pressing the  button, without needing to enter a PIN number or go through all of the other options. Each setpoint can individually have this option enabled or disabled. Refer to Section 7.

6.3 Edit setpoint 2

- A** **___ EDIT SETPOINT** scrolls across the bottom row and **Skip** appears in the top row. Press **(P)** to skip to 6.4 or use the **(▲)** and **(▼)** buttons to select **SP 2**, and then press **(P)**.

SP 1 will also be available from this menu. If you would like to edit SP1, please go back and follow the instructions in Section 6.2.



- B** **___ SP VALUE** scrolls across the bottom row and the last setpoint value entered appears in the top row. Using the **(▲)** and **(▼)** buttons, adjust the display value at which the setpoint will activate. Then press **(P)**.

- C** **___ VOLUMETRIC PULSE** scrolls across the bottom row and the current setting appears in the top row. Use the **(▲)** and **(▼)** buttons to select **Off** or **On**. Press **(P)**.



When the selected setpoint is activated in volumetric pulse mode, the primary counter will reset to 0 and then resume counting. The selected relay will activate for the pulse time specified in 6.3D.





If you selected **Off** in 6.3C:

D ___ **SP ACTIVATION** scrolls across the bottom row and the last selected setpoint activation appears in the top row. Using the  and  buttons, select the relay activation to operate **Above** or **Below** the setpoint value, and then press .



*Select **Above** for the relay to turn on above the setpoint value and off below it. Select **Below** for the relay to turn on below the setpoint value and off above it.*

___ **MAKE DELAY** scrolls across the bottom row and the current selection appears in the top row. Adjust using the  and  buttons, and press .

This defines the delay between setpoint activation and when the relay turns on. This value is in tenths of a second.



___ **BREAK DELAY** scrolls across the bottom row and the current selection appears in the top row. Adjust using the  and  buttons, and press .



This defines the delay between setpoint de-activation and when the relay turns off. This value is in tenths of a second.

___ **TRAIL SP1** scrolls across the bottom row and the current selection appears in the top row. Select **Off** or **On** using the  and  buttons. Press .

*If you choose **On**, SP 2 will be automatically adjusted whenever SP 1 is changed, so that the 2 setpoints always trail each other by the same amount.*

If you selected On, skip the rest of this step.



___ **SETPOINT SOURCE** scrolls across the bottom row and the currently selected setpoint source appears in the top row. Using the  and  buttons, select: **Prm Cntr**, **B Cntr**, **C Cntr**, **Rate** or **A+B+C**. Then press .

___ **USER ACCESS?** scrolls across the bottom row and the last selected direct access setting appears in the top row. Using the  and  buttons, select either **Off** or **On**. Then press .



When enabled, this allows the setpoint value to be edited directly after pressing the  button. See Section 7.







If you selected **On** in 6.3C:

D ___ **PULSE TIME** scrolls across the display and toggles with the currently selected pulse time. Use the  and  buttons to select your pulse time (from 0.1 to 10.0 seconds), and then press .

Pulse reset requires a minimum of 0.1 seconds. A combination of high input rates and low setpoint values may exceed this limitation, resulting in missed output pulses.

___ **SETPOINT SOURCE** scrolls across the bottom row and the currently selected setpoint source appears in the top row. Using the  and  buttons, select: **Prm Cntr**, **B Cntr** or **C Cntr**. Then press .

___ **USER ACCESS?** scrolls across the bottom row and the last selected direct access setting appears in the top row. Using the  and  buttons, select either **Off** or **On**. Then press .

When enabled, this allows the setpoint value to be edited directly after pressing the  button. See Section 7.

E **___** **EDIT SETPOINT** scrolls across the bottom row and **Skip** appears in the top row. If you have finished editing setpoints, press **P** now to proceed to 6.4.

If you would like to edit **SP 1** or **SP 2**, use the **▲** and **▼** buttons to select the required setpoint and then press **P**. Then go to Section 6.2 (for **SP 1**), or Section 6.3 (for **SP 2**).

6.4 Edit setpoint PIN

- A** ___ **EDIT SP PIN NUMBER** scrolls across the bottom row and **Skip** appears in the top row. Press **P** to skip and return to the operational display, or the **▲** button and then **P** to **Enter**.
- B** ___ **ENTER NEW SP PIN NUMBER** scrolls across the bottom row and the current PIN (default 1) appears in the top row. Using the **▲** and **▼** buttons, enter your new setpoint entry PIN number. Then press **P** to **Exit** and return to the operational display.

7 SETPOINT DIRECT ACCESS

If neither of the setpoints have their direct access option enabled then this feature will be disabled and the **F2** button will not respond to a short button press.



7.1 Setpoint direct access

- A** Begin by pressing the **F2** button for less than 3 seconds. The setpoint name (**SP 1** or **SP 2**) will appear in the bottom row and the current setpoint value will appear in the top row. Using the **▲** and **▼** buttons, adjust the selected value. Then press **P** to accept the new setpoint value.
- B** If any other setpoints have the direct access option enabled then the same process is repeated for the next setpoint. Pressing **P** for the last enabled setpoint will exit and return to the operational display.

A

APPENDIX A
Reset PIN numbers

If you have forgotten either of your PIN numbers, follow the procedure below to reset both the calibration and setpoint entry PIN's to their factory default of 1.

- A** Press ,  and  at the same time. (This key combination can be difficult to execute and you may need several tries to get it right.)

- B** When successful, a factory identification text will scroll across the display, followed by: **_ _ _ ALL PIN NUMBERS RESET TO 1.**

- C** Reset the PIN numbers individually as required by following the instructions in Sections 5.7 and 6.4, entering '1' whenever you are prompted for your current PIN.

B

APPENDIX B
Display shortcuts

- ▲ Press the ▲ button for $\frac{1}{2}$ a second to enter the display shortcuts menu. Pressing ▲ repeatedly will now allow you to scroll through the current values for **Rate**, **Prim Cnt** (primary counter) and **Peak**. Press P to return to the operational display.
- ▼ Press the ▼ button for $\frac{1}{2}$ a second to enter the display shortcuts menu. Pressing ▼ repeatedly will now allow you to scroll through the current values for **C Count**, **B Count** and **Valley**. Press P to return to the operational display.

To reset peak or valley, press both the ▲ and ▼ buttons together while the required parameter is being displayed.

C

APPENDIX C

Primary & B Input Count Modes

This section outlines the count modes available on the A and B counters. See Appendix D (p53) for C input count modes. Refer to Section 5.2B (p18) to configure your SC - CTR controller for your required count mode.

QUAD x 1

This is the most commonly used counter function, and is shown for a shaft encoder in this example. Depending on the direction of rotation, the A signal either leads or lags the B signal.

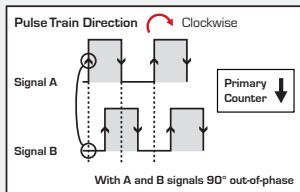

Primary counter decrements:

- on a **rising** edge A signal when B is **low**

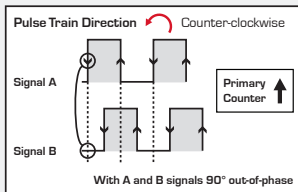

Primary counter increments:

- on a **falling** edge A signal when B is **low**

QUAD x 2

In this mode, the angular/linear resolution of the x 1 mode is increased by 2. Depending on the direction of rotation, the A signal leads or lags the B signal. This example is for a shaft encoder.

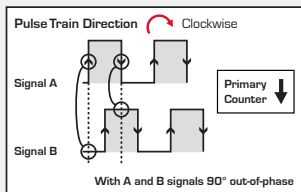

Primary counter decrements:

- on a **rising** edge A signal when B is **low**
- on a **falling** edge A signal when B is **high**

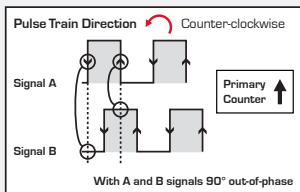

Primary counter increments:

- on a **rising** edge A signal when B is **high**
- on a **falling** edge A signal when B is **low**

QUAD x 4

In this mode, the angular/linear resolution of the x 1 mode is increased by 4. Depending on the direction of rotation, the A signal leads or lags the B signal. This example is for a shaft encoder.

▶▶ Continues ▶▶

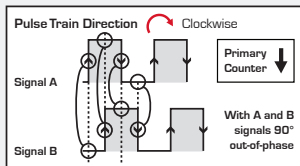
**Primary counter decrements:**

- on a **rising** edge A signal when B is **low**
- on a **rising** edge B signal when A is **high**
- on a **falling** edge A signal when B is **high**
- on a **falling** edge B signal when A is **low**

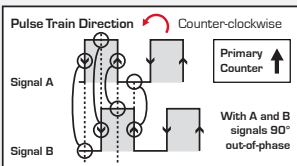
**Primary counter increments:**

- on a **rising** edge A signal when B is **high**
- on a **rising** edge B signal when A is **low**
- on a **falling** edge A signal when B is **low**
- on a **falling** edge B signal when A is **high**

A + B

In this mode there is no fixed relationship between signals A and B.

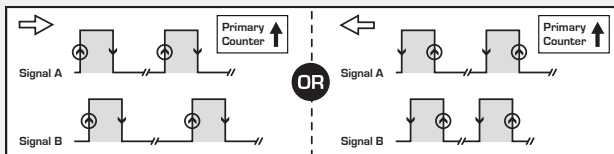
**Primary counter increments:**

- on a **rising** edge A signal
- on a **rising** edge B signal

A - B

In this mode the A and B signals are linked in a phase relationship. Signal A increments the primary counter on every rising edge, while signal B decrements the primary counter on every rising edge.

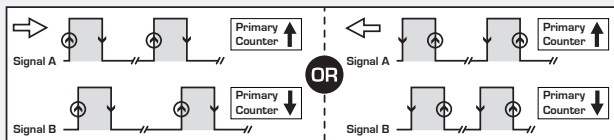

Primary counter increments:

- on a rising edge A signal

And decrements:

- on a rising edge B signal

A & B INDEPENDENT

In this mode there is no fixed relationship between signals A and B. Signal A increments the primary counter on every rising edge, and signal B increments the secondary counter on every rising edge.

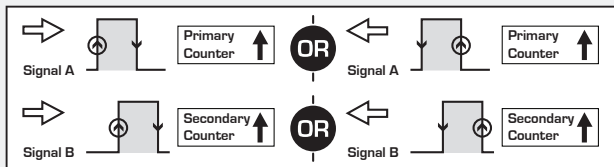

Primary counter increments:

- on a rising edge A signal

Secondary counter increments:

- on a rising edge B signal

UP / DOWN

In this mode the A and B signals are linked in a phase relationship. Signal A increments the primary counter on every rising edge when signal B is low. Signal A also decrements the primary counter on every rising edge when signal B is high.

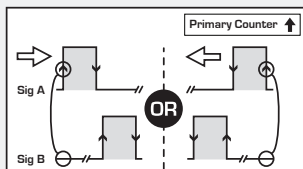

Primary counter increments:

- on a **rising** edge A signal when B is low

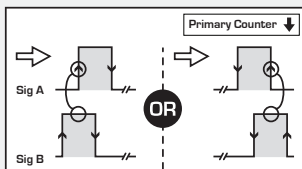

Primary counter decrements:

- on a **rising** edge A signal when B is high

D

APPENDIX D
C Input Count Modes

This section outlines the count modes available on the C counter. See Appendix C (p48) for primary and B input count modes. Refer to Section 6.2B (p19) to configure your SC - CTR controller for your required count mode.

COUNT

In this mode the **primary** counter **increments** on a **rising** edge C signal only. This is particularly useful for multi-input systems.

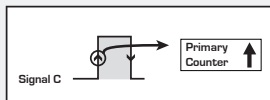

RSOF A/B

(Reset to offset A, B mode)

In this mode the **primary** and **secondary** counters are reset to the values stored in the meter's reset offset registers, and they continue counting after being reset. This is useful for setting a position to a known reference position.

▶▶ Continues ▶▶

On a **falling edge** C signal:

- **Primary** counter is reset to value stored in **primary reset offset register**
- **Secondary** counter is reset to value stored in **secondary reset offset register**
- **Both counters** continue to count after being reset

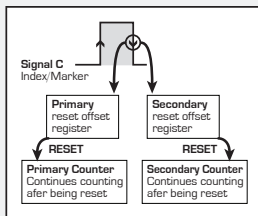

RSOFSTAB

(Reset to offset and start A, B mode)

In this mode the **primary** and **secondary** counters are reset to the values stored in the meter's reset offset registers, and they continue counting after being reset.

On a **rising edge** C signal:

- **Both counters** begin counting

On a **falling edge** C signal:

- **Primary** counter is reset to value stored in **primary reset offset register**
- **Secondary** counter is reset to value stored in **secondary reset offset register**
- Both counters continue to count after being reset

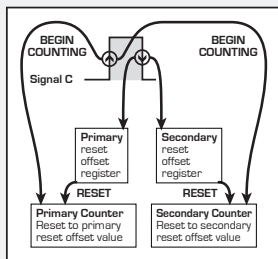



Copyright © 2009 Texmate NZ Ltd.
10B Vega Place, Mairangi Bay
North Shore City 0632, New Zealand

Ph: +64 (9) 835-1550
Fax: +64 (9) 835-1250
Email: info@texmate.co.nz
Web: www.texmate.co.nz



SC - CTR

**DOCUMENT REVISION CODE:
SC-CTR-MAN-09-V.01**