

TM - 2L

UNIVERSAL TRANSMITTER

USB programmable!

Driver & manual at:
www.texmate.co.nz/tm

TM - 2L COMMON SPECIFICATIONS



<i>Configuration</i>	2-wire 4~20mA (loop powered)
<i>Power supply</i>	9.5–36V DC
<i>Supply voltage sensitivity</i>	$< \pm 0.005\% / V_{FSO}$
<i>Output load resistance</i>	700 Ω at 24V DC (50 Ω/V above 9.5V DC)
<i>Maximum output current</i>	Limited to $< 28mA$ (Emission and immunity)
<i>Emissions compliance</i>	EMC EN 61326
<i>Immunity compliance</i>	EMC EN 61326
<i>Safety compliance</i>	EMC EN 61010-1
<i>Accurate to</i>	$< \pm 0.03\% FSO$ TYPICAL
<i>Ambient drift</i>	$< \pm 0.003\% / ^\circ C$ FSO TYPICAL
<i>Noise immunity</i>	125dB CMRR AVERAGE (2.0kV DC limit)
<i>R.F. immunity</i>	$< 1\%$ effect FSO TYPICAL
<i>Isolation test voltages</i>	Between input and output: 3750V AC for 1 min
<i>Response time</i>	400msec TYPICAL (10–90% 300msec TYPICAL)
<i>Operating temperature</i>	-20–+85 $^\circ C$
<i>Storage temperature</i>	-20–+100 $^\circ C$
<i>Operating humidity</i>	5–85%RH MAX (non-condensing)
<i>Mounting</i>	35mm symmetrical DIN rail
<i>Dimensions</i>	79 x 20 x 68mm (H x W x D)

WIRING KEY

- (A)** USB
- (B)** Zero
- (C)** LED

INPUT

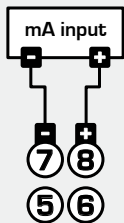
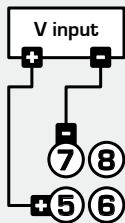

Potentiometer

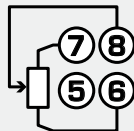

mV Input



3-wire RTD

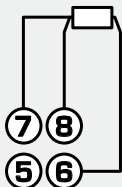

Thermocouple

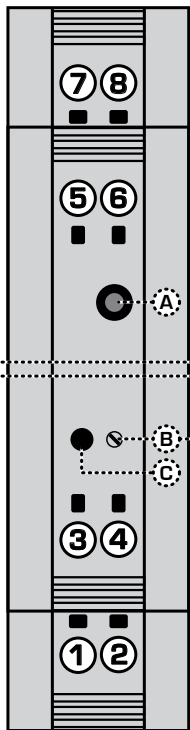

INPUT

OUTPUT

3750V isolation barrier

WARNING!
ZERO ADJ
WILL UPSET
ALL RANGE
CALIBRATION

**INCORRECT
POLARITY
MAY CAUSE
DAMAGE!**

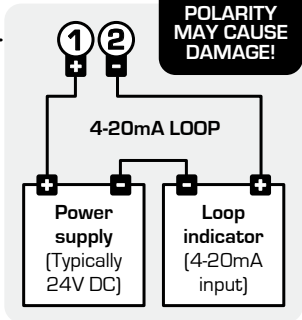

VOLTAGE INPUT SPECIFICATIONS

<i>USB programmable zero</i>	0–±99% of the span
<i>USB programmable span</i>	100mV to +/-10V DC (bipolar)
<i>Input resistance</i>	300k Ω MIN
<i>Maximum over-range</i>	60V DC continuous
<i>Linearity and repeatability</i>	<±0.02% FSD TYPICAL

CURRENT INPUT SPECIFICATIONS

<i>USB programmable zero</i>	0–±99% of the span
<i>Field programmable span</i>	1 μ A–24mA DC
<i>Input resistance</i>	10 Ω
<i>Maximum over-range</i>	50mA DC continuous
<i>Linearity and repeatability</i>	<±0.02% FSD TYPICAL

T/C INPUT SPECIFICATIONS

<i>Thermocouple types</i>	B, E, J, K, N, R, S, T
<i>USB programmable zero</i>	0–±99% of the span
<i>Field programmable span</i>	Refer to ordering information for min/ max ranges for each type
<i>Input impedance</i>	1M Ω MIN
<i>T/C lead resistance</i>	100 Ω MAX
<i>Cold junction comp.</i>	-20–+90 $^{\circ}$ C
<i>Accuracy</i>	E, J, K, N, T < ±1 $^{\circ}$ C B, R, S < ±2 $^{\circ}$ C
<i>Temperature drift</i>	E, J, K, N, T < ±0.05 $^{\circ}$ C B, R, S < ±0.2 $^{\circ}$ C
<i>CJC error</i>	< ±1 $^{\circ}$ C
<i>Sensor break output drive</i>	Function downscale Function upscale

RTD INPUT SPECIFICATIONS

<i>RTD input</i>	Pt100 or Pt1000 DIN 3-wire type. (2-wire can be used with offset calibration)
<i>Sensor current</i>	0.15mA nominal
<i>Lead wire resistance</i>	Pt100: 10 Ω /wire MAX Pt1000: 5 Ω /wire MAX 0.02% FSO offset error per Ω of lead resistance
<i>USB programmable zero</i>	0- \pm 99% of the span
<i>USB programmable span</i>	-200-+850 $^{\circ}$ C
<i>Sensor break output drive</i>	Function high upscale / low downscale
<i>Linearity (Pt100)</i>	0.02% FSO for span inputs \leq 200 $^{\circ}$ C. 0.1% FSO for span inputs \leq 850 $^{\circ}$ C
<i>Linearity (Pt1000)</i>	0.02% FSO for span inputs \leq 200 $^{\circ}$ C. 0.2% FSO for span inputs \leq 520 $^{\circ}$ C
<i>Other available RTD types</i>	JIS, Pt100/1000, Pt392, Cu10

POTENTIOMETER INPUT SPECIFICATIONS

<i>Potentiometer input</i>	3-wire potentiometer
<i>Excitation voltage</i>	1.2V DC
<i>Potentiometer resistance</i>	0-2K Ω LOW POT, 0-1M Ω HIGH POT
<i>Field programmable zero</i>	0-90% of the span
<i>Field programmable span</i>	0.1-100%
<i>Linearity and repeatability</i>	$<\pm$ 0.02% FSO TYPICAL



PH +64 (9) 835-1550
FAX +64 (9) 835-1250
AUS 1800 810 820

www.texmate.co.nz

[MAR-10] TM-2L-MAN-10-V.02