



WALL-MOUNT PROCESS CONTROLLER

**WM - PRC Setup Manual
R8 (A/S/AS)**

CONTENTS

1 - Introduction	1
2 - Specifications	2
3 - Diagrams	4
4 - Input Header Configuration	7
5 - Wiring	10
6 - Setup & Calibration	15
7 - Setpoint Setup	30
8 - Setpoint Direct Access	36
9 - Reset PIN Numbers	37
10 - Display Shortcuts	38

1 INTRODUCTION

Designed specifically for use in process applications, the WM - PRC accepts 0-20mA, 4-20mA, 0-2V or 0-10V inputs. It is supplied pre-mounted in a ready-to-hang box, making it simple to install.

This controller includes a backlit, transfective LCD display, dual 16-character display rows and 5 front panel buttons for easy setup and operator interface. It also features a hinged transparent dust and splash cover, making it ideal for a variety of industrial environments.

The WM - PRC is available as a standard base unit with 8 relays [R8], and can also be purchased with the addition of an analog output [R8A], a serial port [R8S], or both [R8AS].

2

SPECIFICATIONS

Input	Current: 0-20mA, 4-20mA or Voltage: 0-2V, 0-10V
Power supply	HV: 85-265V AC/95-370V DC or LV: 15-48V AC/10-72V DC
Relay outputs	8 x 5A Form A relays
Sampling rate	10Hz
Resolution	16-bit
Accuracy	0.05% of reading
Temperature drift	Typically 50ppm/°C
Calibration	Factory pre-calibrated - automatic or manual user calibration available
Security	Setup is PIN code protected
Case	185 x 235 x 119mm (H x W x D) Wall-mount

OPTIONAL OUTPUTS**Analog output**

Isolated 16-bit 4-20mA/0-10V output (fully scaleable).
Window programmable over full-scale range.

Serial port

Isolated RS232 **or** RS485

Modes: Texmate ASCII, Modbus RTU slave, Ranger A

Data rates: 1200-115k2 baud.

Parity: Odd/even/none

HEADER SELECTABLE OPTIONS

Input range (*factory default=20mA*)

20mA

Custom

2V

10V

3 DIAGRAMS

The WM - PRC has a dual 16-digit alphanumeric LCD display, five front-panel buttons and four setpoint annunciators.

BUTTON PRESS FUNCTIONS

Refer to 3.1, Fig 1

- F1** This button is used to access the **input setup and calibration** menu. See Section 6.

- P** This button is typically used to save your settings and advance to the next step in the process.

- ▲** This button is typically used to scroll through options or increase values in the setup menu. Pressing this button from the main display will show the current **Peak** value (see Section 10).

- ▼** This button is typically used to scroll through options or decrease values in the setup menu. Pressing this button from the main display will show the current **Valley** value (see Section 10).

- F2** This button is used to access the **setpoint setup menu** (see Section 7) and the **setpoint direct access** menu (see Section 8).

3.1 Fig 1 - Faceplate view

Refer to the table above (p4) for button press functions

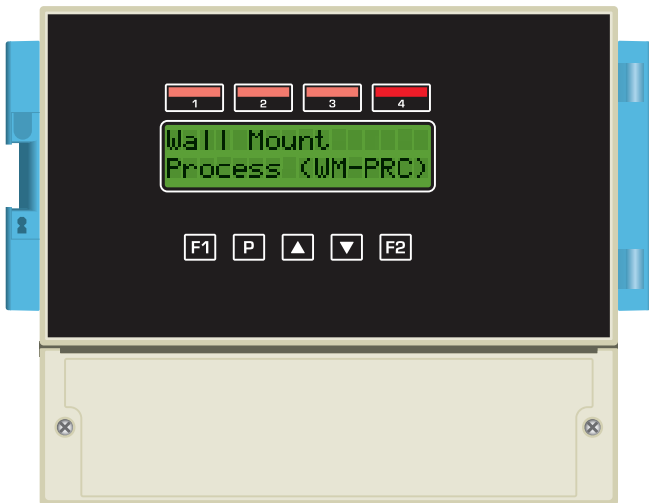

3.2 Fig 2 - Wiring view

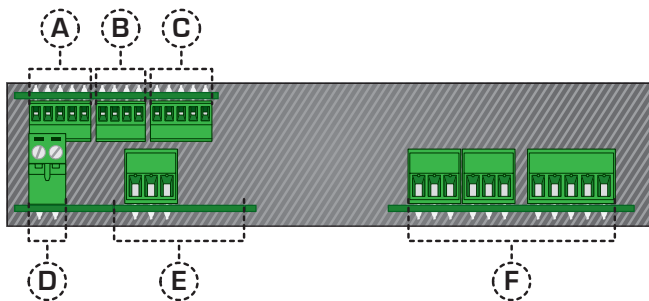

CONNECTOR PINS

- | | |
|---|---|
| <p>(A) Serial port -
Wiring: Section 5.5</p> | <p>(D) Power supply (HV/LV) -
Wiring: Section 5.1</p> |
| <p>(B) Function pins -
Wiring: Section 5.6</p> | <p>(E) IP07 input module -
Header setup: Section 4
Wiring: Section 5.2</p> |
| <p>(C) Analog output -
Wiring: Section 5.4</p> | <p>(F) 8 x relay outputs -
Wiring: Section 5.3</p> |

Some models do not include (A) and/or (C).

4 INPUT HEADER CONFIGURATION

Before you can begin wiring, the IPO7 input module header must be positioned for your input type (factory default=20mA). Follow the instructions below to detach the input module from the main board.

4.1 Remove the input module

Refer to 3.2, Fig 2E

Step 1

Remove the screws from either side of the input module

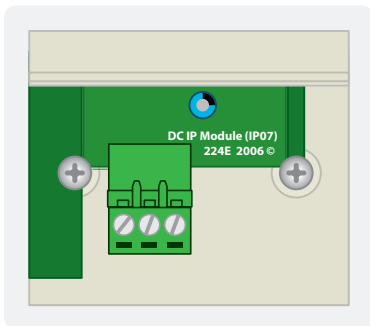

Step 2

Slide the input module forward, keeping it level with the main board until it 'clicks' out

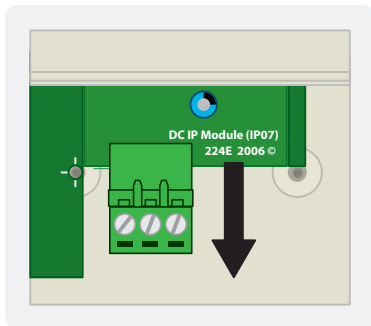

4.2 Position the input header

INPUT HEADER

20mA	Current input - 0-20mA or 4-20mA	2V	Voltage input - 0-2V
Custom	Custom input - call for options	10V	Voltage input - 0-10V

The IP07 input module has one header, which may need to be repositioned to suit your application. (Refer to the table above.)

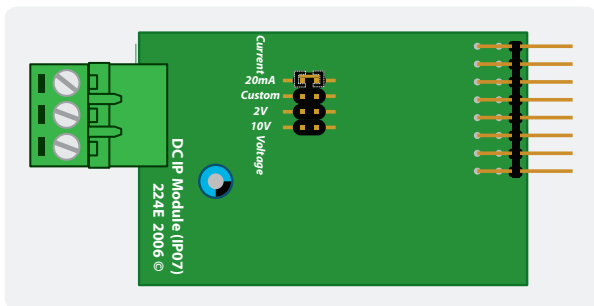

Once you have positioned the input header as required, slide the input module back into its original position and replace the screws.

Take care that the input module board is level with the main board, and the header connector at the far end is properly connected.

5 WIRING

Before you begin:

Check the label on the unit to determine whether your controller is configured for low or high voltage power supply.

5.1 Connect your controller to the power supply

Refer to 3.2, Fig 2D

Make sure your power supply is turned off, and then wire it as shown.

LV 15-48V AC/10-72V DC

HV 85-265V AC/95-370V DC

NEVER connect your low voltage controller to mains power.

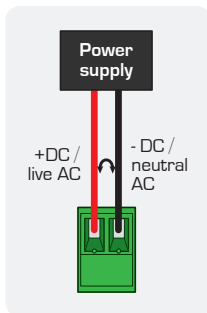

5.2 Wire your IP07 analog input module

Refer to 3.2, Fig 2E

Make sure that you have completed Section 4 before you begin wiring your input module.

2-wire current or voltage process input

External excitation used

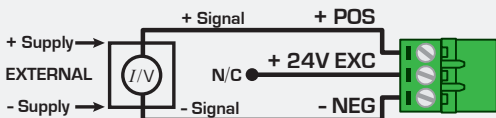

3-wire current or voltage process input

Controller supplied excitation

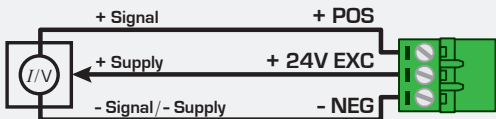

2-wire current input
Loop powered sensor

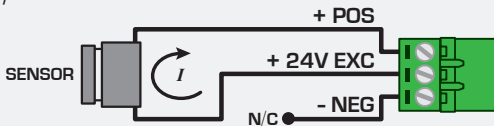

5.3 Wire your relays

Refer to 3.2, Fig 2F

Wire your relays as shown.

WM - PRC relays can be programmed to operate within the total span range of the controller.

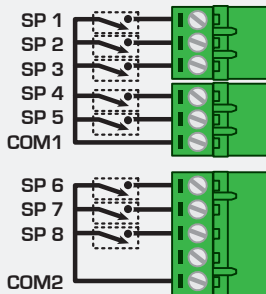

5.4 Wire your analog output (if fitted)

Refer to 3.2, Fig 2C

If your controller has an analog output fitted, wire it as shown.

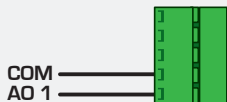

If you do not have an analog output fitted then step 5.4 is skipped.

5.5 Wire your serial port (if fitted)

Refer to 3.2, Fig 2A

If your controller has a serial port fitted, wire it as shown.



If you do not have a serial port fitted then step 5.5 is skipped.

5.6 Wire your function pins

Refer to 3.2, Fig 2B

Connect external switches (as shown below) to enable a function to be executed when its switch is activated.

Peak - Clears the peak reading

Hold - Holds the display value

Valley - Clears the valley reading

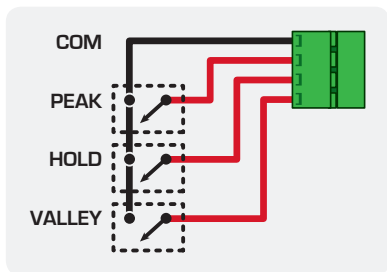

5.7 Power up your controller

Once you have completed the wiring process it is safe to switch on your power supply. Ensure that your display is functioning before you proceed.

6 SETUP & CALIBRATION

Enter the setup and calibration mode by pressing **F1**.

6.1 Enter calibration PIN

A **__ _ ENTER CAL PIN NUMBER** scrolls across the bottom row and **0** appears in the top row. Use the **▲** and **▼** buttons to enter your security code (factory default 1). Then press **P**. If the correct PIN is entered then the setup is started at 6.2.

If an incorrect PIN number is entered, **__ _ INCORRECT PIN NUMBER - ACCESS DENIED** scrolls across the display and it returns to the normal operating mode.



You will be given the opportunity to change your PIN number at the end of this section (6.7). If you have forgotten your PIN number, see Section 9.



6.2 Input setup

Input defaults are set to 4-20mA, 50Hz, no decimal and no rounding.

- A** ___ **INPUT SETUP** scrolls across the bottom row and **Skip** appears in the top row. Press **P** to skip to 6.3, or the **▲** button and then **P** to **Enter** input setup.
- B** ___ **MAINS FREQUENCY** scrolls across the bottom row and the currently selected mains frequency appears in the top row. Using the **▲** and **▼** buttons, select either **50Hz** or **60Hz**. Then press **P**.
- C** ___ **INPUT MODE** scrolls across the bottom row and the currently selected input mode appears in the top row. Using the **▲** and **▼** buttons, select: **4-20mA**, **0-20mA**, **2 Volts** or **10 Volts**. Then press **P**.

If you opt to change the input mode in this section then the header plug on the input module must also be changed to match. See Section 4 for more information.

D **___ DECIMAL POINT POSITION** scrolls across the bottom row and the currently selected decimal point position appears in the top row. Use the  and  buttons to choose between: **No DP**, **0.1**, **0.12**, **0.123**, **0.1234** or **0.12345**, and then press .

E **___ DISPLAY ROUNDING** scrolls across the bottom row and the currently selected display rounding appears in the top row. Using the  and  buttons, select: **None**, **2**, **5** or **10**. Then press .

Rounding is quoted in display counts and is not influenced by decimal point position. For example, if your input signal is 5.3mA, the display will show: 5.3 (for rounding=None), 5.4 (for rounding=2), 5.5 (for rounding=5) or 5.0 (for rounding=10).

6.3 Calibration

A _ _ _ **CALIBRATION TECHNIQUE** scrolls across the bottom row and **Skip** appears in the top row. Press **P** to skip to 6.4, or use the **▲** and **▼** buttons select either **Auto**, **Manual** or **S.G.** (specific gravity), and then press **P**.

Auto - The automatic (key-in) 2-point calibration procedure uses zero and span values to calculate the scale and offset. This is the most accurate calibration method, but requires known low and high input signals (or the use of a calibrator).

Manual - The manual calibration procedure uses low and high display values, and is intended for a pre-calibrated sensor with a known output range. (For example 4mA=0 and 20mA=1000.) It does not require any input signals to be applied to the controller during calibration.

S.G. - The specific gravity calibration procedure allows the user to enter a scale factor which is used to compensate for changes in the specific gravity of different substances. **This does not constitute a full calibration and assumes that either an automatic or manual calibration has been applied previously with the S.G. value set to 1.0.**



If you selected Auto in 6.3A:

B ___ APPLY LOW INPUT SIGNAL - - - - ENTER

LOW DISPLAY VALUE scrolls across the display.

Apply the required low input signal to the controller.

Using the  and  buttons, enter your low end

display value. Then press  to accept.

___ APPLY HIGH INPUT SIGNAL - - - - ENTER

HIGH DISPLAY VALUE scrolls across the display.

Apply the required high input signal to the controller.

Using the  and  buttons, enter your high end

display value. Press . If calibration is successful,

the controller will return to the operational display.



___ CALIBRATION FAILED



A calibration failure results when the controller cannot detect any change in input signal during the calibration procedure.

After viewing this message you will be redirected to the operational display. Check your input signal and connections, and then repeat the process.





If you selected **Manual** in 6.3A:

C ___ **ENTER DISPLAY VALUE FOR (X)** scrolls across. (X=**0/4mA** or **0 VOLTS**, depending on your selection in 6.2C.) Using the  and  buttons, enter your display value for the selected low input signal. Press .

___ **ENTER DISPLAY VALUE FOR (X)** scrolls across. (X=**20mA** or **2/10 VOLTS**, depending on your selection in 6.2C.) Using the  and  buttons, enter your display value for the selected high input signal. Then press  to accept the new calibration values and return to the operational display.



If you selected **S.G.** in 6.3A:

D ___ **SPECIFIC GRAVITY** scrolls across and the current specific gravity scale factor appears. Adjust this value using the  and  buttons, and then press  to accept and return to the operational display.

6.4 Averaging

▶▶ 6.4 Quick Access from operating mode ▶▶



Press and hold \square . Use \square & \square to enter PIN. Press \square 3 times.

- A **___ AVERAGING PARAMETERS** scrolls across the bottom row and **Skip** appears in the top row. Press \square to skip to 6.5, or the \square button and then \square to **Enter** averaging parameters setup.

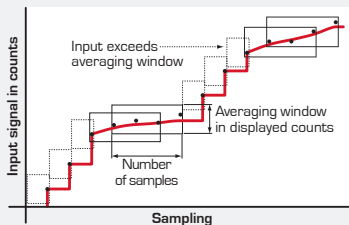

Your controller has input signal averaging, guaranteeing stable measurement.

If the input exceeds the averaging window value it will not average, ensuring fast response.



- B** **___ AVE SAMPLES** scrolls across the bottom row and the currently selected averaging appears in the top row. Using the  and  buttons, alter the number of input samples that the controller will average, and then press .

Increasing the number of samples will stabilise measurement, but it will also slow down response rates.

- C** **___ AVE WINDOW** scrolls across the bottom row and the currently selected averaging window value appears in the top row. Using the  and  buttons, alter the signal averaging window. Then press .

If your input signal contains large noise spikes, then you can increase the size of averaging window to ensure that these pulses are still averaged. However, increasing the averaging window too far will reduce the ability of the controller to respond quickly to real changes in input signal.

6.5 Analog output setup

If your controller does not have this option installed then you will not view this section - setup will continue at 6.6.

A _ _ _ **ANALOG OUTPUT SETUP** scrolls across the bottom row and **Skip** appears in the top row. Press **(P)** to skip to 6.6, or the **(▲)** button and then **(P)** to **Enter** analog output setup.

B _ _ _ **LOW SCALE VALUE FOR ANALOG OUTPUT** scrolls across the bottom row and the currently selected low scale value appears in the top row. Use the **(▲)** and **(▼)** buttons to set the low scale value. Then press **(P)**.
This sets the display value for cal low (as at 6.5E).

C _ _ _ **HIGH SCALE VALUE FOR ANALOG OUTPUT** scrolls across the bottom row and the currently selected high scale value appears in the top row. Use the **(▲)** and **(▼)** buttons to set the high scale value. Then press **(P)**.
This sets the display value for cal high (as at 6.5F).

- D** **___ CALIBRATE ANALOG OUTPUT?** scrolls across the bottom row and **Skip** appears in the top row. If you do not wish to calibrate your analog output now then press **(P)** to skip the rest of this section and proceed to 6.6.

Otherwise, press the **(▲)** button to **Enter** analog output calibration. **Before continuing, connect a milliamp meter across the analog output connector.** Then press **(P)**.

- E** **___ CAL LOW ANALOG OUTPUT** scrolls across the bottom row and a calibration number appears in the top row. Using the **(▲)** and **(▼)** buttons, calibrate your low analog output as required. Then press **(P)**.

- F** **___ CAL HIGH ANALOG OUTPUT** scrolls across the bottom row and a calibration number appears in the top row. Using the **(▲)** and **(▼)** buttons, calibrate your high analog output as required. Then press **(P)**.

6.6 Serial setup

If your controller does not have this option installed then you will not view this section - setup will continue at 6.7.









A ___ **SERIAL SETUP** scrolls across the bottom row and **Skip** appears in the top row. Press **[P]** to skip to 6.7, or the **[▲]** button and then **[P]** to **Enter** serial setup.

B _ _ _ **SERIAL MODE** scrolls across the bottom row and the currently selected serial mode appears in the top row. Using the **[▲]** and **[▼]** buttons, select either: **ASCII, Modbus (RTU)** or **Ranger A**. Then press **[P]**.

***ASCII** - Texmate **ASCII** is a simple protocol that allows connection to various Texmate PC configuration tools.*

***Modbus** - Industry standard RTU slave mode that allows connection to a wide range of devices, such as PC's or PLC's.*

***Ranger A** - This is a continuous output, used to drive remote displays and other instruments in the Rinstrum™ range. (Ranger is a tradename belonging to Rinstrum Pty Ltd.)*

- C** ___ **BAUD RATE** scrolls across the bottom row and the currently selected baud rate appears in the top row. Use the  and  buttons to choose between: **1200, 2400, 4800, 9600, 19200, 38400, 57600** or **115200**. Then press .
- D** ___ **PARITY** scrolls across the bottom row and the currently selected parity appears in the top row. Use the  and  buttons to select: **None, Odd** or **Even**. Then press .
- E** ___ **SERIAL ADDRESS** scrolls across the bottom row and the currently selected serial address appears in the top row. Use the  and  buttons to alter the serial address. Then press .

The serial address parameter is used to identify a particular device when it is used with other devices in a system. [It applies particularly to Modbus mode when used on a RS485 network.] The serial address of the controller must be set to match the serial address used in the master device.

▶▶ More info on registers ▶▶

See Tables [p27-28]

MODBUS REGISTERS - These are all holding registers and should be accessed via function codes 3 and 6.

Register addresses are displayed in the Modicon™ addressing format. i.e. Register 65=40065 (subtract 1 for direct addressing).

16-BIT UNSIGNED	
40239	Alarm status <i>(Bit0=SP1, Bit1=SP2 etc.)</i>
44181	SP 1 hysteresis
44182	SP 2 hysteresis
44183	SP 3 hysteresis
44184	SP 4 hysteresis
44185	SP 5 hysteresis
44186	SP 6 hysteresis
44187	SP 7 hysteresis
44188	SP 8 hysteresis
44197	SP 1 make delay
44198	SP 2 make delay
44199	SP 3 make delay
44200	SP 4 make delay
44201	SP 5 make delay
44202	SP 6 make delay
44203	SP 7 make delay
44204	SP 8 make delay

8-BIT UNSIGNED	
48208	Baudrate
48212	Serial address
48216	Serial mode

32-BIT SIGNED (2x16-bit)	
40001	Process display
40057	Peak
40059	Valley
40111	SP 1
40113	SP 2
40115	SP 3
40117	SP 4
40119	SP 5
40121	SP 6
40123	SP 7
40125	SP 8
40381	D/A scale low
40405	D/A scale high

RANGER A - This allows the SC to drive a remote display from the Rinstrum range. The following shows the output string format when Ranger A output is selected:

<Start> <Sign> <Output Value> <Status> <End>

<i>STRING CHARACTER(S)</i>	
<Start>	STX character (ASCII 02)
<Sign>	Output value sign (space for + and dash for -)
<Output Value>	Seven character ASCII string containing the current output value and decimal point. <i>(If there is no decimal point, then the first character is a space. Leading zero blanking applies.)</i>
<Status>	Single character output value status: U=Under, O=Over, E=Error
<End>	ETX character (ASCII 03)

6.7 Edit calibration PIN

- A** _ _ _ **EDIT CAL PIN NUMBER** scrolls across the bottom row and **Skip** appears in the top row. Press **P** to skip and return to the operational display, or the **▲** button and then **P** to **Enter**.
- B** _ _ _ **ENTER NEW CAL PIN NUMBER** scrolls across the bottom row and the current PIN (default 1) appears in the top row. Using the **▲** and **▼** buttons, enter your new calibration PIN number. Then press **P** to exit and return to the operational display.

7 SETPOINT SETUP

Enter the setpoint setup mode by pressing and holding the **F2** button for 3 seconds.

7.1 Enter setpoint PIN

A **_ _ _ ENTER SP PIN NUMBER** scrolls across the bottom row and **0** appears in the top row. Use the **▲** and **▼** buttons to enter your security code (factory default 1). Then press **P**. If the correct PIN is entered then the setup is started at 7.2.



If an incorrect PIN number is entered, **_ _ _ INCORRECT PIN NUMBER - ACCESS DENIED** scrolls across the display and it returns to the normal operating mode.

You will be given the opportunity to change your PIN number at the end of this section (7.3). If you have forgotten your PIN number, see Section 9.

7.2 Edit setpoints

- A** _ _ _ **EDIT SETPOINT** scrolls across the bottom row and **Skip** appears in the top row. Press **P** to skip to 7.3, or use the **▲** and **▼** buttons to select a setpoint to edit (**SP 1 - SP 8**). Then press **P**.
- B** _ _ _ **SP VALUE** scrolls across the bottom row and the last setpoint value entered appears in the top row. Using the **▲** and **▼** buttons, adjust the display value at which the setpoint will activate. Then press **P**.
- C** _ _ _ **SP ACTIVATION** scrolls across the bottom row and the last selected setpoint activation appears in the top row. Using the **▲** and **▼** buttons, select the relay activation to operate **Above** or **Below** the setpoint value, and then press **P**.

*Select **Above** for the relay to turn on above the setpoint value and off below it. Select **Below** for the relay to turn on below the setpoint value and off above it.*

- D **___ SETPOINT TYPE** scrolls across the bottom row and the last selected setpoint type appears in the top row. Using the  and  buttons, select either **Alarm** or **Control**. Then press .

Alarm - The **setpoint value** controls the point at which the setpoint will activate. The **hysteresis value** controls the point at which the setpoint will deactivate.

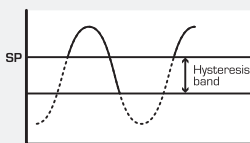

Energised Above

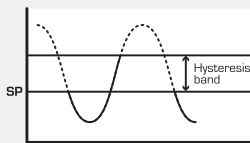

Energised Below

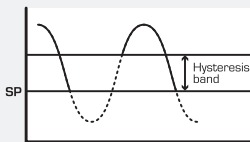

Control - The **setpoint value** controls the point at which the setpoint will deactivate. The **hysteresis value** controls the point at which the setpoint will reactivate.



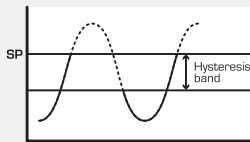

Energised Above





Energised Below

- E** ___ **HYSTERESIS VALUE** scrolls across the bottom row and the current value appears in the top row. Use the  and  buttons to alter the hysteresis value if required. Then press .

*The hysteresis value defines the separation band between setpoint activation and deactivation. Hysteresis will operate as per the specified type setting (**Alarm** or **Control**) - see 7.2D.*

- F** ___ **MAKE DELAY** scrolls across the bottom row and the last selected make delay value appears in the top row. Adjust the make delay value using the  and  buttons and then press .

The make delay value defines the delay between setpoint activation and when the relay turns on. This value is in tenths of a second.



- G** ___ **OPEN ACCESS TO SP VALUE** scrolls across the bottom row and the last selected direct access setting appears in the top row. Using the  and  buttons, select either **No** or **Yes**, and then press .

When enabled, this option allows the setpoint value to be edited directly after pressing the  button, without needing to enter a PIN number or go through all of the other options. Each setpoint can individually have this option enabled or disabled.



If you selected **SP 1** in 7.2A:

Skip 7.2H and continue to 7.2I now.

H _ _ _ **TRAIL SP1** scrolls across the bottom row and the current trailing setting appears in the top row. Using the  and  buttons, select either **Off** or **On**, and then press .

*If you choose **On**, the selected setpoint will become an offset value, which is effectively added to the value of **SP 1**.*

I _ _ _ **EDIT SETPOINT** scrolls across the bottom row and **Skip** appears in the top row. You are now back at 7.2A.

To edit another setpoint, follow the instructions from 7.2A-I again. If you have finished editing setpoints, press  now to **Skip** to 7.3.

7.3 Edit setpoint PIN

- A** ___ **EDIT SP PIN NUMBER** scrolls across the bottom row and **Skip** appears in the top row. Press **P** to skip the rest of this section and return to the operational display, or the **▲** button and then **P** to **Enter**.
- B** ___ **ENTER NEW SP PIN NUMBER** scrolls across the bottom row and the current PIN (default 1) appears in the top row. Using the **▲** and **▼** buttons, enter your new setpoint entry PIN number. Then press **P** to exit and return to the operational display.

8 SETPOINT DIRECT ACCESS

If none of the setpoints have their direct access option enabled then the **F2** button will not respond to a short press. (See 7.2G to enable.)



8.1 Setpoint direct access

- A** Begin by pressing the **F2** button for half a second. The name of the first access-enabled setpoint (**SP 1 – SP 8**) will appear in the bottom row and the current value for that setpoint will appear in the top row. Using the **▲** and **▼** buttons, adjust the selected value. Then press **P** to accept and progress to the next access-enabled setpoint.
- B** Pressing **P** for the last access-enabled setpoint will exit and return to the operational display.

9 RESET PIN NUMBERS

If you have forgotten your PIN number, follow the procedure below to reset the calibration and setpoint entry PIN numbers to their factory default of 1.



9.1 Reset PIN numbers



- A** Press ,  and  at the same time. (This key combination can be difficult to execute and you may need several tries to get it right.)
- B** When successful, a factory identification text will scroll across the display, followed by: **_ _ _ ALL PIN NUMBERS RESET TO 1.**
- C** Reset the calibration PIN numbers if required by following the instructions in Sections 6.7 and 7.3.



10 DISPLAY SHORTCUTS

Use these shortcuts for quick viewing of specified parameters from the operational display.

10.1 Peak and valley

To view the maximum (peak) value - press the  button for ½ a second. The word **Peak** appears in the bottom row and the maximum measured process input value appears in the top row. Press  to return to the operational display.

To view the minimum (valley) value - press the  button for ½ a second. The word **Valley** appears in the bottom row and the minimum measured process input value appears in the top row. Press  to return to the operational display.

To reset peak or valley - press both the  and  buttons together while the required parameter is being displayed.



Copyright © 2009 Texmate NZ Ltd.
10B Vega Place, Mairangi Bay,
North Shore City 0632, New Zealand

Ph: +64 (9) 835-1550
Fax: +64 (9) 835-1250
Email: info@texmate.co.nz
Web: www.texmate.co.nz



WM - PRC

DOCUMENT REVISION CODE:
WM-PRC-MAN-09-V.01